

TICA, Visible Cleanness · TICA, Visible Energy-Saving

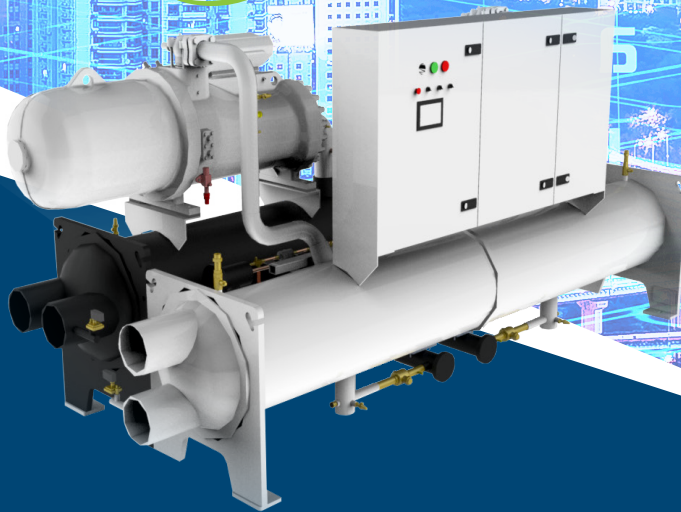

TICA Central Air Conditioner Water-cooled Flooded Screw Chiller (Heat Pump)

Established in 1991

TICA is a professional enterprise specialized in R&D, manufacturing, sales and services of environment cleaning and thermal energy utilization.

TICA is a national high-tech enterprise, a single leading enterprise cultivated by the Ministry of Industry and Information Technology, a national brand cultivation enterprise of the Ministry of Industry and Information Technology, and a vice chairman member of China Refrigeration and Air-conditioning Industry Association. It has a national-recognized enterprise technology center, an enterprise academician workstation, and a post-doctoral research workstation. Its projects cover Beijing Bird's Nest Stadium, Water Cube, Wukesong Indoor Stadium, PetroChina, Sinopec, State Grid, Nanjing Panda, Hangzhou Xiaoshan International Airport, Hainan Airlines Group, Shangri-La Hotel, Manila Ocean Park, Abu Dhabi Al Muneera, SM City in Philippines and Unilever, etc.

TICA is also the outstanding provider of central air conditioners for China's subway networks and has successfully served nearly 60 key subway lines in major cities such as Beijing, Shanghai, Guangzhou, Shenzhen, Chengdu, Suzhou, Hangzhou and Tianjin. TICA is a professional supplier and service provider in China that specializes in system integration of clean environment. While for microelectronics, hospital operating rooms, biopharmaceutical industry and other professional purification areas, our market share has achieved over 40% in each.

TICA Quality For IAQ

TICA focuses on indoor air quality (IAQ) in clean environments. Product lines include return air purifiers, heat recovery ventilators, fresh air purifiers, air purifiers, as well as the clean air handling units and digital variable-capacity air handling units used in the professional purification field. Regarding core technology, TICA established an ISO class 1 super-clean environment integration system and won the first prize of CMIST.

TICA's product lines include modular chillers, VRF units, screw chillers, centrifugal chillers, and ORC low-temperature waste heat power generation systems. In 2015, TICA and United Technologies Corporation (UTC) established a global strategic joint venture cooperation relationship and acquired PureCycle, an ORC low-temperature power generation company owned by Pratt & Whitney under UTC. TICA obtained PureCycle trademarks and more than 100 patents and national copyrights. TICA's efficient centrifugal chillers, water-cooled screw chillers, and air-cooled screw chillers are manufactured with the technical license of Carrier under UTC.

TICA is characterized by excellent system integration capability. In the application of "Efficient Refrigeration System of Underground Railway Station", the integrated COP of the refrigeration room amounts to 6.0, and the research achievement reaches the international advanced level. In 2018, TICA merged and acquired an OFC central air conditioning enterprise **SMARTD**. TICA's excellent system integration capability and the **SMARTD** OFC water chillers help increase the integrated COP of the efficient equipment room to 6.7 to 7.0.

TICA---We're striving.

TICA aims to build itself into a world-leading system integration supplier and service provider that specializes in clean environment and thermal energy utilization.



Water-cooled Flooded Screw Chiller (Heat Pump)

CONTENTS

Overview	2
Features	3
Specifications	6
Technical Parameter Correction Factor Diagram	13
Customizable Component	18
Unit Dimensions	21
Lifting Diagram	24
Installation and Maintenance	26
Selection of Water System Parts	30
Check Items before Startup	31
Routine Maintenance	33

TICA owns five production sites in Nanjing, Tianjin, Guangzhou, Chengdu and Kuala Lumpur, and a network of over 70 sales and service outlets around the world.

Its Nanjing HQ base received 3-star certification for national No. 001 green industrial construction.



Nanjing Headquarters



Tianjin Base



Guangzhou Base



Chengdu Base

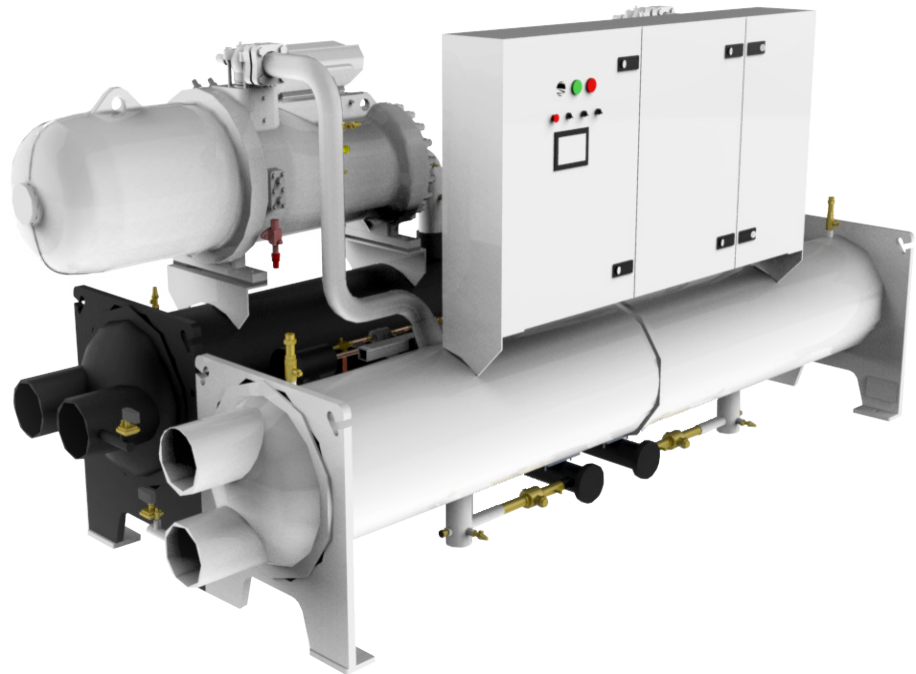

TICA water-cooled flooded screw chiller adopts a compact design and is equipped with the flooded evaporator, semi-hermetic double-screw compressor and high efficient heat exchanger. Together with the advanced microcomputer control technology, the chiller is highly stable and reliable, and features efficient and quiet operations. Available in a variety of models, the units are ideal for scenarios requiring comfort and process cooling.

TICA water source heat pump units use underground water, surface water, sewage, sea water, and soil as cold and heat sources, and provide cooling in summer and heating in winter. The operating conditions are stable throughout the year, and the cooling and heating capacities can be better developed; without the needs for any cooling towers, there is minimized impact on the surroundings and the operating costs are greatly reduced.

Nomenclature

TWSF 0120 . 1 F W 1 A

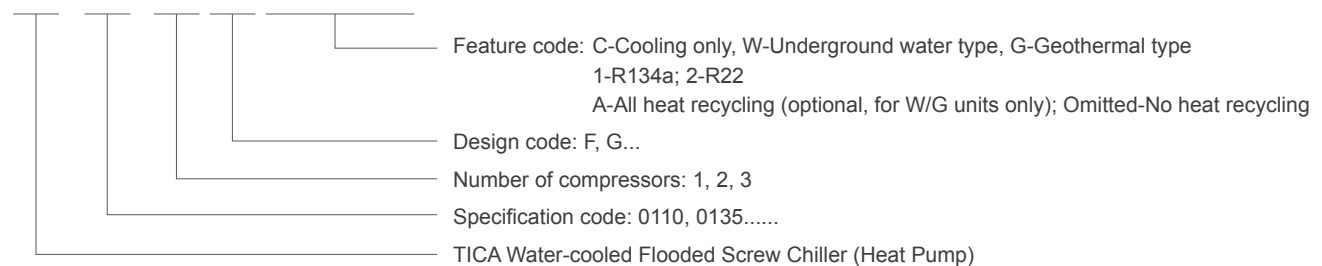

Water-cooled Flooded Screw Chiller (Heat Pump)

Features

1. Internationally Recognized Quality



The units have passed the certification of the Air-Conditioning, Heating and Refrigeration Institute (AHRI) and China Refrigeration and Air-Conditioning Industry Association (CRAA).

The units are up to the AHRI551/991-2011 standard (AHRI is considered to be the most prestigious organization in the international refrigeration industry).

Both TICA unit performance test bench and independently developed unit selection software have passed the AHRI certification. Every unit has to pass the test on the test bench recognized by AHRI before delivery.

TICA laboratory has obtained national CNAS certification.

2. High Efficiency & Energy Saving

TICA's water-cooled flooded screw chillers have all met National EEI level 2, some of which have met National EEI level 1.

- ◆ German patented, semi-hermetic double-screw compressor enables the unit to operate efficiently in both full-load and partial-load conditions.
- ◆ Evaporator and condenser equipped with enhanced heat exchange tubes improve the heat transfer efficiency and reduce the power consumption.
- ◆ TICA's unique dynamic optimization and control algorithms allow the unit to operate efficiently under different operating conditions.

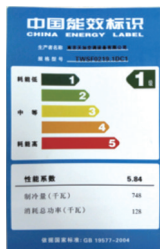

Energy Efficiency Label



Authentication certificate of energy saving products



Energy saving test report

3. Advanced Technology

Efficient German compressor

- ◆ The double-screw compressor special for German patented water-cooled unit boasts high adiabatic efficiency. The high-efficiency and large-capacity motor helps significantly reduce power consumption of the unit, enabling the unit to operate efficiently in full load or partial load.
- ◆ The three-stage oil separator of the compressor works with efficiency up to 99.5%.
- ◆ With the stepless regulation of the slide valve, a single compressor can match 25%–100% load change, and a dual head unit can implement 12.5%–100% load change.
- ◆ The screw rotor is processed with patented technology, and its micron-level precision ensures precise engagement and long service life.
- ◆ The compressor motor cools down by air suction to ensure long service life, and the complete protection function guarantees safe operation of the unit.
- ◆ Super high-efficiency series are equipped with GB19577 standard compressor to ensure that their energy efficiency reaches national EEI level 1; the units also use efficient motor specially tailored to China's power supply conditions, to ensure that the compressor operates efficiently for both full-load and partial-load conditions; Bizter smart module control technology allows monitoring the units in real time, including their voltage, temperature, pressure and operating condition, to ensure reliable operation.

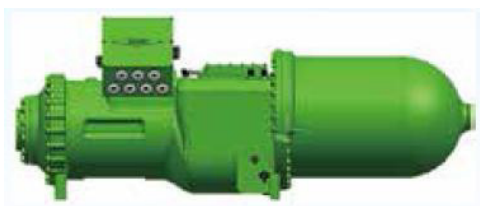
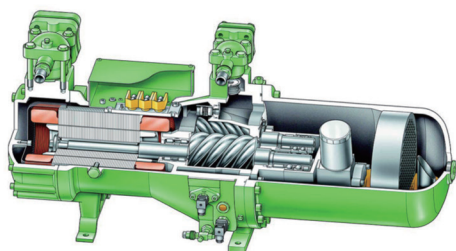

Brand new high-efficiency heat exchanger

- ◆ The shell-and-tube type, flooded evaporator features newly arranged and enhanced bilateral heat exchange tubes to guarantee efficient heat exchange; uses CFD simulation to calculate and design liquid baffle to balance the air field, ensuring liquid level stability, and absorbing air only instead of liquid and guaranteeing stable operation.

- ◆ The shell-and-tube type condenser features built-in TICA's patented oil separator, allowing the oil separation efficiency to be up to 99.9% combined with the compressor embedded oil separator; uses CFD simulation to calculate and analyze sub-cooling part, and increases the refrigerant's supercooling degree by 2-3 times, ensuring that liquid supply pipes are free of gaseous refrigerant and the unit operates efficiently and reliably.

- ◆ The detachable lid makes it easy to cleanse the inside of heat exchange tubes, thereby ensuring high efficiency of heat exchanging.

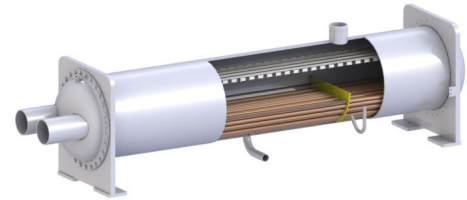

Sophisticated throttle apparatus and unique oil return

- ◆ The sophisticated EXV features accurate control, fast speed of response, and a wide range of regulation, allowing the unit to operate reliably whether under full load or partial load.

- ◆ The continuous oil return technology – oil injected by oil – adopts the cutting-edge, special injection pump to inject the remaining 0.1% oil in the evaporator into the compressor to ensure safe and reliable running of the compressor.

- ◆ With TICA's patented technology of automatic oil injection, the system will automatically start oil-injection control program when the oil level in the compressor reaches the low limit, ensuring the compressor's safe and efficient operation.

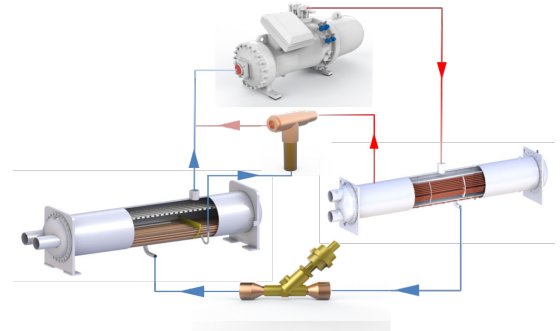

Compact and easy to install

- ◆ Both the evaporator and condenser are configured with flanges and clamps to make field installation convenient.

- ◆ The unit requires a small floor area due to the compact structure.

- ◆ The refrigerant water flow ranges from 40% to 110% of the nominal flow, making it more suitable for flow variable primary pump.

- ◆ The unit is configured with a compressor startup cabinet, to facilitate on-site cable connection by the user.

- ◆ The unit is properly insulated.

- ◆ With minimal vibration, the unit is equipped with 4 pieces of 30mm chloroprene rubber shock-absorbing cushions.

- ◆ Sufficient refrigerant has been charged in the unit before the entire unit is delivered.

- ◆ During installation on site, users only need to connect the water pipes of evaporator and condenser and connect the power supply.



4. Precise Control System and Reliable Operation

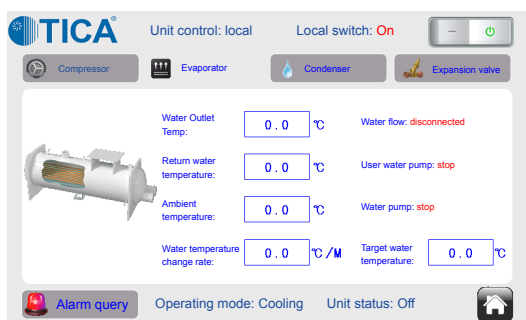

◆ Sophisticated control system

—The industrial-level microcomputer controller, together with the 7-inch colored touch screen, constitutes the control unit of the unit. As a result, the unit is rather reliable and jamproof and therefore ideal for complicated, hostile working environments.

◆ Unique dynamic optimization and control algorithms

—Benefiting from TICA's years of experience in air conditioning design and application, the control algorithms feature more precise calculation of unit load; the algorithms are integrated with TICA's unique dynamic optimization and control to allow the units to make adjustments in all operating conditions and to ensure the units are keeping running in an efficient, reliable and secure manner; The refrigerant water flow ranges from 40% to 110% of the nominal flow, making it more suitable for flow variable primary pump.

◆ Intelligent control

—The advanced pre-control function enables measures to be taken promptly before actual failure occurs to avoid unexpected shutdown of the unit due to an alarm.

—Multiple compressors can operate automatically to reach a load balance and therefore can prolong the service life of the unit.

—Each compressor and circuit can be controlled independently and can serve as the standby for another compressor, minimizing the impact of possible faults.

—Unique oil return control technology resolves the issue of oil separation.

—Benefiting from the fuzzy control technology, the unit is able to adjust the water temperature based on outdoor air temperature and hence can enhance efficiency to the greatest extent while meeting the needs.

—The unit supports the compiling of weekly operating schedules to implement comprehensive automatic start and stop control of the unit, and can truly be left unattended.

◆ Complete safety protection

—Power supply protection: phase loss, reverse phase, over-voltage, and under-voltage

—Compressor protection: protection for motor overheat, overload, frequent startup, oil level and high discharge temperature

—Pressure protection: both evaporator and condenser are equipped with safety valves, and have protection when low pressure is too low, high pressure is too high, and protection for low air suction/discharge pressure difference.

—Other protection: too low water temperature protection, too low water flow protection, sensor failure protection, etc.

◆ Flexible and convenient group communication

—Standard RS485 interface and MODBUS RTU protocol are provided, and the unit is connected to the building automation system (BAS), which implements centralized control and remote monitoring of the unit and control of other attached devices according to the controlling requirement of the BAS.

◆ Creative wireless communication technology (optional)

—The configured wireless communication module provides Ethernet connection and supports wireless short message prompt function. Users can access the unit parameters by sending short messages. The unit can automatically send short messages to the specified end-number when an alert is generated. In this way, users can access the running condition of the unit anytime anywhere.

Water-cooled Flooded Screw Chiller (Heat Pump)

Specifications

Parameters of TWSF-FC1 (R134a) flooded-type water-cooled screw chiller High-efficiency series

Model	TWSF-FC1	0110.1	0135.1	0160.1	0175.1	0200.1	0220.1	0240.1	0265.1		
Cooling capacity	Ton	110	135	156	175	200	215	235	260		
	10 ⁴ kcal/h	33	41	47	53	60	65	71	79		
	kW	387	475	547	615	703	755	825	915		
Power input	kW	65	80	91	102	116	125	136	151		
Efficiency	kW/Ton	0.591	0.592	0.583	0.583	0.580	0.582	0.580	0.580		
COP	W/W	5.95	5.94	6.01	6.03	6.06	6.04	6.07	6.06		
Running current	A	121	141	162	176	208	215	232	260		
Starting current	A	330	415	479	506	650	650	683	845		
Compressor quantity	Set	1	1	1	1	1	1	1	1		
Power supply	380 V 3N-50 Hz										
Refrigerant	R134a										
Energy control	Stepless regulation of energy										
Evaporator	Design pressure on water side	Mpa	1.0								
	Water flow	m ³ /h	67	82	94	106	121	130	142	157	
	Water pressure drop	kPa	74	72	73	72	73	74	75	86	
	Piping DN	mm	150	150	150	150	150	150	150	150	
Condenser	Design pressure on water side	Mpa	1.0								
	Water flow	m ³ /h	78	96	110	123	141	151	165	183	
	Water pressure drop	kPa	86	77	87	86	85	72	78	68	
	Piping DN	mm	150	150	150	150	200	200	200	200	
Dimensions	Length	mm	3122	3122	3122	3122	3144	3144	3144	3144	
	Width	mm	1500	1500	1500	1500	1550	1550	1550	1550	
	Height	mm	1800	1800	1800	1800	1850	1850	1850	1850	
Shipping weight	kg	2750	3200	3250	3350	3800	3850	4000	4150		
Operating weight	kg	2950	3450	3490	3590	4150	4180	4400	4500		

★ Note:

1. The parameters under above operating conditions: are as follows: chilled water outlet temperature 7°C, chilled water inlet temperature 30°C.
2. For technical parameters under non-standard operating conditions, please contact branches of TICA.
3. The maximum startup current listed in the table is the current under Y-Δ startup mode.
4. Power supply: 380V 3N-50Hz; allowable voltage fluctuation: ±10%.
5. Standard water chamber pressure: 1.0 MPa; optional water chamber pressure: 1.6 MPa, 2.0 MPa.
6. Specification parameters are subject to change without prior notice, due to product improvement.



	0280.2	0300.2	0325.2	0350.2	0370.2	0390.2	0410.2	0430.2	0450.2	0465.2	0495.2	0510.2
	277	293	316	340	367	392	409	425	441	461	486	507
	84	89	95	103	111	119	124	129	133	139	147	153
	973	1030	1110	1194	1292	1379	1438	1495	1551	1620	1710	1782
	161	171	184	198	215	228	238	245	255	267	281	293
	0.582	0.584	0.583	0.583	0.585	0.581	0.582	0.576	0.578	0.579	0.578	0.578
	6.04	6.02	6.03	6.03	6.01	6.05	6.04	6.10	6.08	6.07	6.09	6.08
	285	301	324	344	360	380	420	430	440	464	490	516
	660	724	759	801	828	972	1013	1013	1048	1081	1243	1278
	2	2	2	2	2	2	2	2	2	2	2	2
380 V 3N-50 Hz												
R134a												
Stepless regulation of energy												
1.0												
	167	177	191	205	222	237	247	257	267	279	294	307
	65	80	72	80	66	65	72	57	63	63	63	62
	200	200	200	200	200	200	200	200	200	200	200	200
1.0												
	195	207	223	240	259	276	288	300	311	325	343	357
	65	83	83	85	57	56	86	56	59	61	60	62
	200	200	200	200	200	200	200	200	200	200	200	200
	4497	4497	4497	4497	4540	4540	4540	4540	4540	4624	4624	4652
	1600	1600	1600	1600	1800	1800	1800	1800	1800	1800	1800	1800
	1950	1950	1950	1950	2050	2050	2050	2050	2050	2050	2050	2050
	6500	6550	6650	6750	7100	7200	7250	7350	7500	7600	7750	7800
	6970	7000	7150	7250	7800	7900	7950	8100	8250	8350	8575	8600

Parameters of TWSF-FW1 (R134a) flooded-type water source screw heat pump unit

Model	TWSF-FW1	0120.1	0140.1	0155.1	0180.1	0210.1	0230.1	0250.1	0270.1		
Cooling capacity	Ton	123	139	150	176	211	227	250	268		
	10 ⁴ kcal/h	37	42	45	53	64	69	75	81		
	kW	434	490	527	620	741	799	878	941		
Heating capacity	10 ⁴ kcal/h	39	44	47	55	66	71	78	84		
	kW	448	506	544	643	769	828	908	976		
Cooling power input	kW	65	74	79	93	110	118	130	139		
Heating power input	kW	86	97	104	124	147	158	173	187		
Cooling efficiency	kW/Ton	0.527	0.531	0.527	0.527	0.522	0.519	0.521	0.519		
Cooling EER	W/W	6.68	6.62	6.67	6.67	6.74	6.77	6.75	6.77		
Heating COP	W/W	5.21	5.22	5.23	5.19	5.23	5.24	5.25	5.22		
Cooling current	A	139	150	165	188	205	216	240	250		
Heating current	A	165	181	208	232	252	258	300	317		
Starting current	A	414	615	683	845	845	845	965	965		
Compressor quantity	Set	1	1	1	1	1	1	1	1		
Cold and hot water-side heat exchanger	Design pressure on water side	Mpa	1.0								
	Water flow	m ³ /h	75	84	91	107	127	137	151	162	
	Water pressure drop	kPa	65	70	67	67	83	82	85	90	
	Piping DN	mm	150	150	150	150	150	150	150	150	
Underground water-side heat exchanger	Design pressure on water side	Mpa	1.0								
	Water flow	m ³ /h	39	44	47	56	67	72	79	84	
	Water pressure drop	kPa	30	26	26	28	28	27	28	26	
	Piping DN	mm	150	150	150	150	200	200	200	200	
Dimensions	Length	mm	3122	3122	3122	3122	3144	3144	3144	3144	
	Width	mm	1500	1500	1500	1500	1550	1550	1550	1550	
	Height	mm	1800	1800	1800	1800	1850	1850	1850	1850	
Shipping weight	kg	2780	3230	3280	3380	3830	3880	4050	4200		
Operating weight	kg	2980	3450	3520	3650	4150	4200	4400	4560		

★ Note:

- The above data is based on the following operating conditions: cooling mode: inlet underground water temperature: 18°C; refrigerant water outlet temperature: 7°C; heating mode: inlet underground water temperature: 15°C; hot water outlet temperature: 45°C;
The maximum hot water outlet temperature in heating mode is 65°C. If the temperature goes beyond 60°C, please contact TICA factory.
- If the unit is required to operate where groundwater temperature difference is significant, please contact TICA factory.
- For technical parameters under non-standard operating conditions, please contact branches of TICA.
- The maximum startup current listed in the table is the current under Y-Δ startup mode.
- Power supply: 380V 3N-50Hz; allowable voltage fluctuation: ±10%.
- Standard water chamber pressure: 1.0 MPa; optional water chamber pressure: 1.6 MPa, 2.0 MPa.
- Specification parameters are subject to change without prior notice, due to product improvement.



WATER-COOLED FLOODED SCREW CHILLER

	0285.2	0305.2	0330.2	0355.2	0375.2	0400.2	0420.2	0440.2	0465.2	0495.2	0520.2	0540.2
	288	301	322	352	375	400	417	441	465	495	517	537
	87	91	97	106	113	121	126	133	141	150	156	162
	1012	1057	1133	1237	1317	1406	1465	1552	1635	1739	1818	1888
	90	94	101	110	118	126	131	139	146	155	163	169
	1047	1094	1174	1285	1372	1464	1525	1614	1700	1804	1891	1965
	152	159	169	184	196	209	217	229	242	256	268	278
	200	209	224	246	262	279	291	307	323	343	361	376
	0.528	0.529	0.524	0.523	0.523	0.523	0.521	0.519	0.520	0.518	0.518	0.518
	6.66	6.65	6.70	6.72	6.72	6.73	6.75	6.78	6.76	6.79	6.78	6.79
	5.24	5.23	5.24	5.22	5.24	5.25	5.24	5.26	5.26	5.26	5.24	5.23
	300	315	330	355	377	395	410	430	455	489	500	510
	359	385	406	430	454	480	502	522	561	618	636	658
	1004	1072	1124	1286	1318	1318	1318	1318	1441	1561	1436	1436
	2	2	2	2	2	2	2	2	2	2	2	2
	1.0											
	174	182	195	213	227	242	252	267	281	299	313	325
	71	86	77	87	70	70	77	62	71	74	73	72
	200	200	200	200	200	200	200	200	200	200	200	200
	1.0											
	91	95	102	111	118	126	132	139	147	156	163	169
	25	26	25	28	25	25	28	27	28	28	28	30
	200	200	200	200	200	200	200	200	200	200	200	200
	4497	4497	4497	4497	4567	4567	4567	4567	4567	4672	4672	4672
	1600	1600	1600	1600	1800	1800	1800	1800	1800	1800	1800	1800
	1950	1950	1950	1950	2050	2050	2050	2050	2050	2050	2050	2050
	6560	6610	6710	6810	7160	7260	7310	7410	7560	7660	7810	7860
	7100	7150	7250	7350	7950	8050	8100	8200	8400	8500	8700	8750

Parameters of TWSF-FG1 (R134a) flooded-type water source screw heat pump unit

Model	TWSF-FG1	0120.1	0140.1	0155.1	0180.1	0210.1	0230.1	0250.1	0270.1		
Cooling capacity	Ton	122	138	148	175	209	225	247	265		
	10 ⁴ kcal/h	37	42	45	53	63	68	75	80		
	kW	429	485	521	614	734	791	869	932		
Heating capacity	10 ⁴ kcal/h	38	43	46	55	65	70	77	83		
	kW	442	500	536	635	760	818	896	963		
Cooling power input	kW	67	75	81	96	112	121	133	142		
Heating power input	kW	86	97	104	124	147	158	172	186		
Cooling efficiency	kW/Ton	0.549	0.544	0.547	0.550	0.537	0.538	0.538	0.536		
Cooling EER	W/W	6.40	6.47	6.43	6.40	6.55	6.54	6.53	6.56		
Heating COP	W/W	5.14	5.15	5.15	5.12	5.17	5.18	5.21	5.18		
Cooling current	A	142	152	167	190	208	219	244	254		
Heating current	A	165	181	208	234	252	258	299	316		
Starting current	A	414	615	683	845	845	845	965	965		
Compressor quantity	Set	1	1	1	1	1	1	1	1		
Cold and hot water-side heat exchanger	Design pressure on water side	Mpa	1.0								
	Water flow	m ³ /h	74	83	90	106	126	136	150	160	
	Water pressure drop	kPa	65	71	65	65	80	81	84	88	
	Piping DN	mm	150	150	150	150	150	150	150	150	
Underground water-side heat exchanger	Design pressure on water side	Mpa	1.0								
	Water flow	m ³ /h	85	96	104	122	145	157	172	185	
	Water pressure drop	kPa	63	79	79	85	66	78	85	70	
	Piping DN	mm	150	150	150	150	200	200	200	200	
Dimensions	Length	mm	3122	3122	3122	3122	3144	3144	3144	3144	
	Width	mm	1500	1500	1500	1500	1550	1550	1550	1550	
	Height	mm	1800	1800	1800	1800	1850	1850	1850	1850	
Shipping weight	kg	2780	3230	3280	3380	3830	3880	4050	4200		
Operating weight	kg	3000	3450	3520	3650	4150	4250	4400	4560		

★ Note:

- The above data is based on the following operating conditions: cooling mode: inlet geothermal water temperature: 25°C; refrigerant water outlet temperature: 7°C; heating mode: inlet geothermal water temperature: 10°C; hot water outlet temperature: 45°C.
The maximum hot water outlet temperature in heating mode is 65°C. If the temperature goes beyond 60°C, please contact TICA factory.
- When the outlet geothermal water temperature is lower than 3°C, glycol solution needs to be added. Refer to Recommended Glycol Solution Concentration for details.
- For technical parameters under non-standard operating conditions, please contact branches of TICA.
- The maximum startup current listed in the table is the current under Y-Δ startup mode.
- Power supply: 380V 3N-50Hz; allowable voltage fluctuation: ±10%.
- Standard water chamber pressure: 1.0 MPa; optional water chamber pressure: 1.6 MPa, 2.0 MPa.
- Specification parameters are subject to change without prior notice, due to product improvement.



WATER-COOLED FLOODED SCREW CHILLER

	0285.2	0305.2	0330.2	0355.2	0375.2	0400.2	0420.2	0440.2	0465.2	0495.2	0520.2	0540.2
	285	297	319	348	371	395	412	437	460	489	511	531
	86	90	96	105	112	120	125	132	139	148	155	160
	1001	1046	1121	1224	1303	1390	1449	1535	1617	1719	1797	1866
	88	92	99	108	116	123	128	136	143	152	159	165
	1025	1071	1150	1259	1344	1435	1494	1581	1664	1766	1850	1923
	155	162	172	188	200	213	222	234	247	263	275	285
	199	208	223	244	261	278	289	305	322	341	359	374
	0.544	0.545	0.539	0.540	0.540	0.539	0.539	0.536	0.537	0.538	0.538	0.537
	6.46	6.46	6.52	6.51	6.52	6.53	6.53	6.56	6.55	6.54	6.53	6.55
	5.15	5.15	5.16	5.16	5.15	5.16	5.17	5.18	5.17	5.18	5.15	5.14
	304	319	334	360	382	400	416	435	461	498	509	519
	358	384	405	428	453	479	500	502	549	607	622	628
	1004	1072	1124	1286	1318	1318	1318	1318	1441	1561	1436	1436
	2	2	2	2	2	2	2	2	2	2	2	2
	1.0											
	172	180	193	211	224	239	249	264	278	296	309	321
	69	83	74	85	67	67	74	60	69	72	70	69
	200	200	200	200	200	200	200	200	200	200	200	200
	1.0											
	199	208	222	243	259	276	287	304	321	341	357	370
	68	84	83	87	57	56	85	59	64	68	66	68
	200	200	200	200	200	200	200	200	200	200	200	200
	4497	4497	4497	4497	4567	4567	4567	4567	4567	4672	4672	4672
	1600	1600	1600	1600	1800	1800	1800	1800	1800	1800	1800	1800
	1950	1950	1950	1950	2050	2050	2050	2050	2050	2050	2050	2050
	6560	6610	6710	6810	7160	7260	7310	7410	7560	7660	7810	7860
	7100	7150	7250	7350	7900	8050	8100	8250	8400	8500	8700	8750

Parameters of TWSF-FC1 (R134a) flooded-type water-cooled screw chiller Super high-efficiency series

Model		TWSF-FC1	0430.1	0450.1	0470.1	0850.2	0900.2	0940.2
Cooling capacity	Ton		429	450	469	854	895	933
	10 ⁴ kcal/h		130	136	142	258	271	282
	kW		1509	1581	1648	3002	3148	3279
Power input	kW		239	250	259	475	496	516
Efficiency	kW/Ton		0.557	0.556	0.553	0.556	0.554	0.553
COP	W/W		6.31	6.32	6.36	6.32	6.35	6.35
Running current	A		404	421	438	803	835	871
Starting current	A		1033	1033	1033	1668	1668	1668
Compressor quantity	Set		1	1	1	2	2	2
Power supply		380 V 3N-50 Hz						
Refrigerant		R134a						
Energy control		Stepless regulation of energy						
Evaporator	Design pressure on water side	Mpa	1.0					
	Water flow	m ³ /h	260	272	284	516	541	564
	Water pressure drop	kPa	60	45	40	60	60	70
	Piping DN	mm	200	200	200	250	250	250
Condenser	Design pressure on water side	Mpa	1.0					
	Water flow	m ³ /h	301	315	328	598	627	653
	Water pressure drop	kPa	40	45	40	80	80	70
	Piping DN	mm	250	250	250	300	300	300
Dimensions	Length	mm	4800	4800	4800	6700	6700	6700
	Width	mm	2260	2260	2260	2700	2700	2700
	Height	mm	2600	2600	2600	2750	2750	2750
Shipping weight		kg	7800	8300	8800	13000	14000	15000
Operating weight		kg	8970	9500	10100	14950	16000	17000

★ Note:

1. The parameters under above operating conditions are as follows: chilled water outlet temperature 7°C, chilled water inlet temperature 30°C.
2. For technical parameters under non-standard operating conditions, please contact branches of TICA.
3. The maximum startup current listed in the table is the current under Y-Δ startup mode.
4. Power supply: 380V 3N-50Hz; allowable voltage fluctuation: ±10%.
5. Standard water chamber pressure: 1.0 MPa; optional water chamber pressure: 1.6 MPa, 2.0 MPa.
6. Specification parameters are subject to change without prior notice, due to product improvement.

Water-cooled Flooded Screw Chiller (Heat Pump)

Technical Parameter Correction Factor Diagram

Cooling capacity correction factor diagram of the water-cooled flooded screw chiller

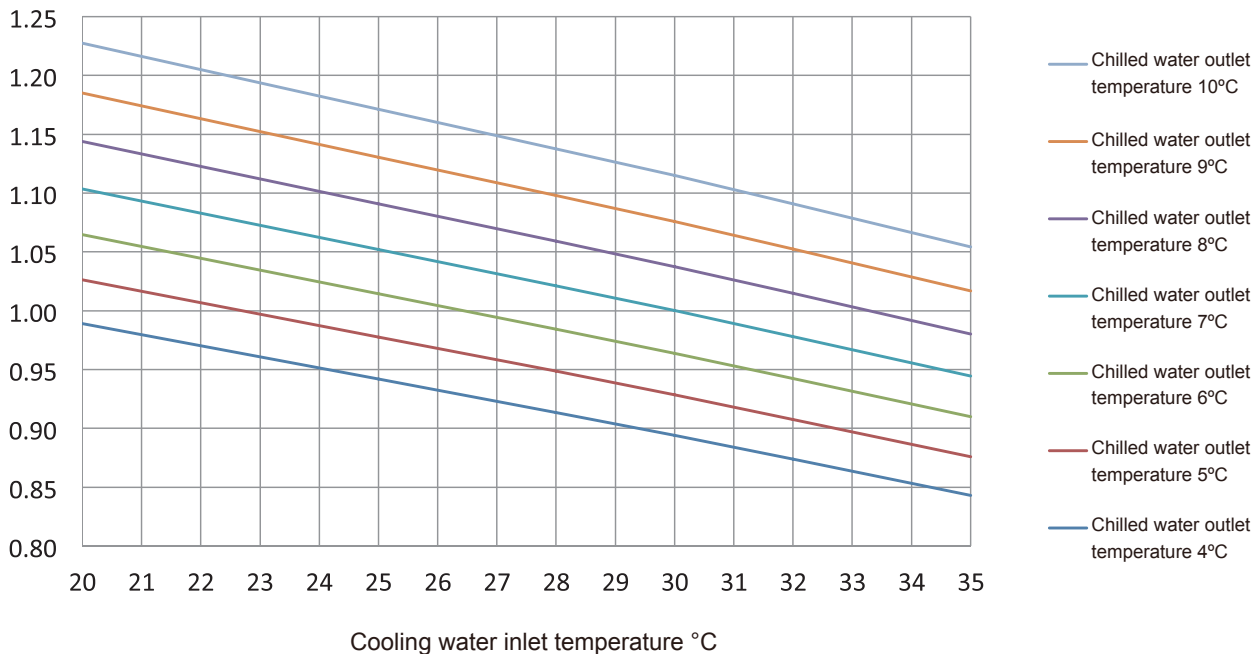

Input power correction factor diagram of the water-cooled flooded screw chiller

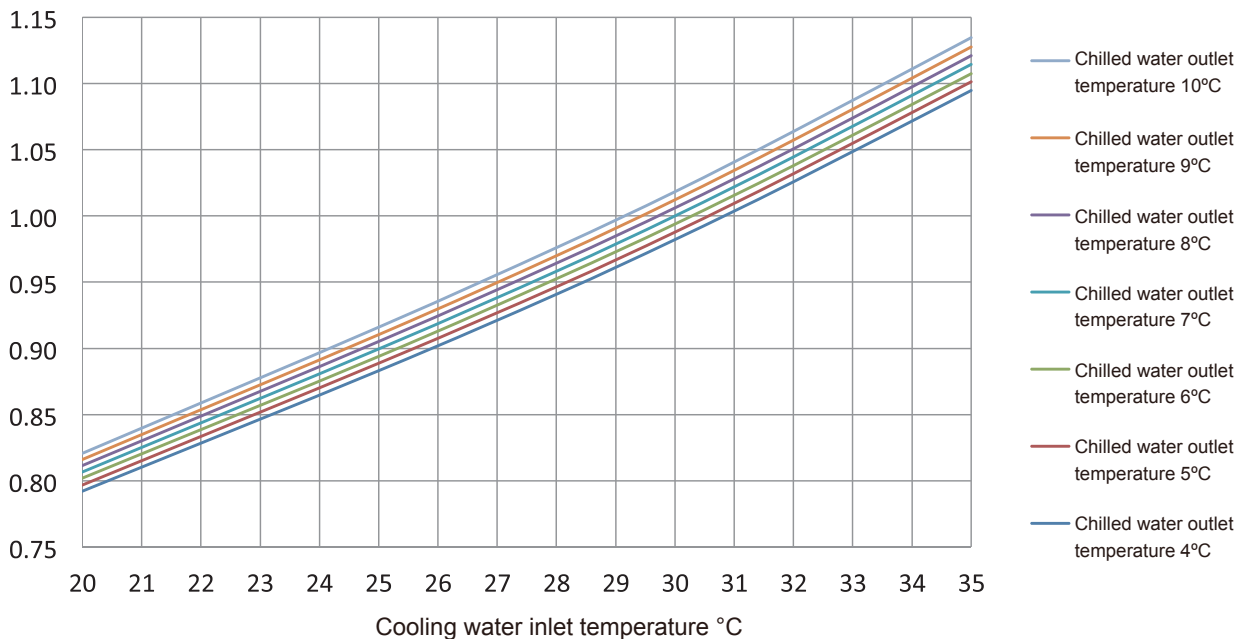

Cooling capacity correction factor diagram of the water source heat pump (underground water) (cooling mode)

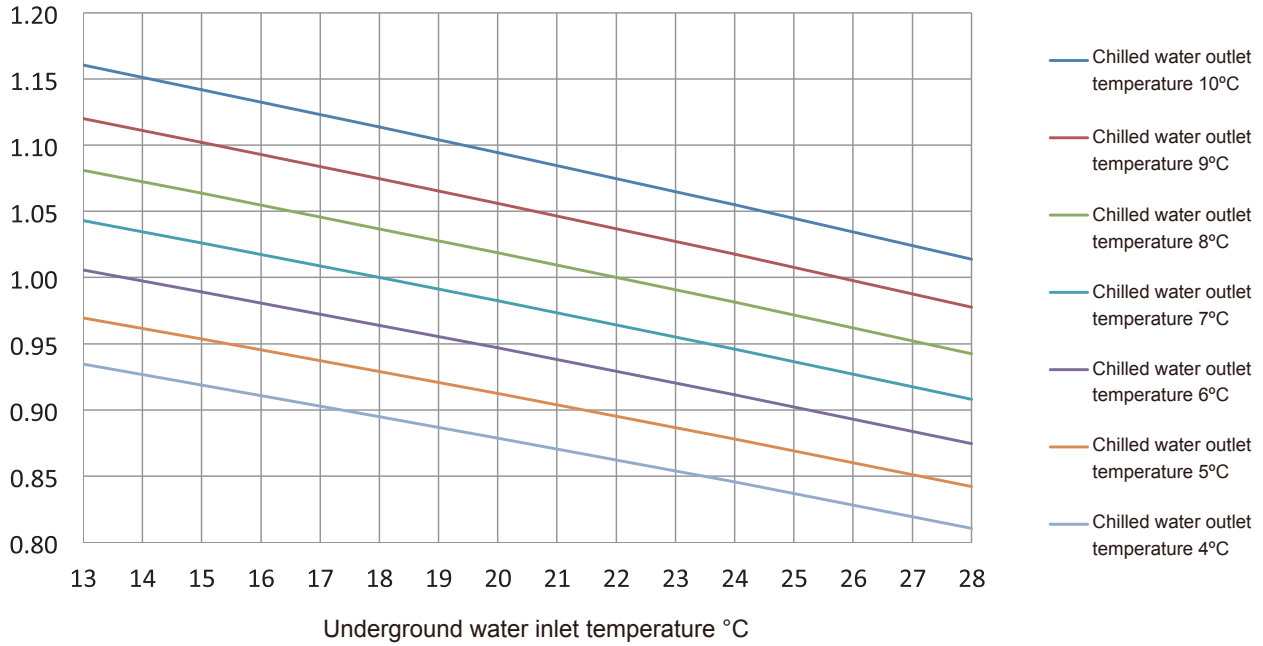

Input power correction factor diagram of the water source heat pump (underground water) (cooling mode)

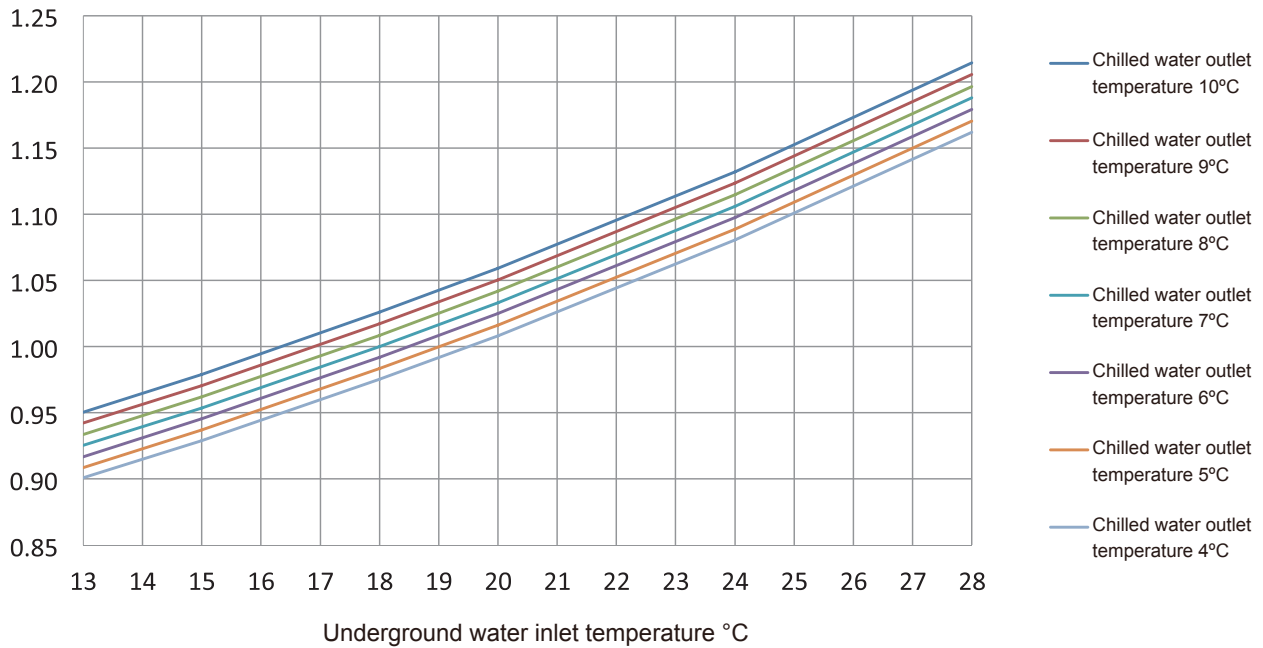

Heating capacity correction factor diagram of the water source heat pump (underground water) (heating mode)

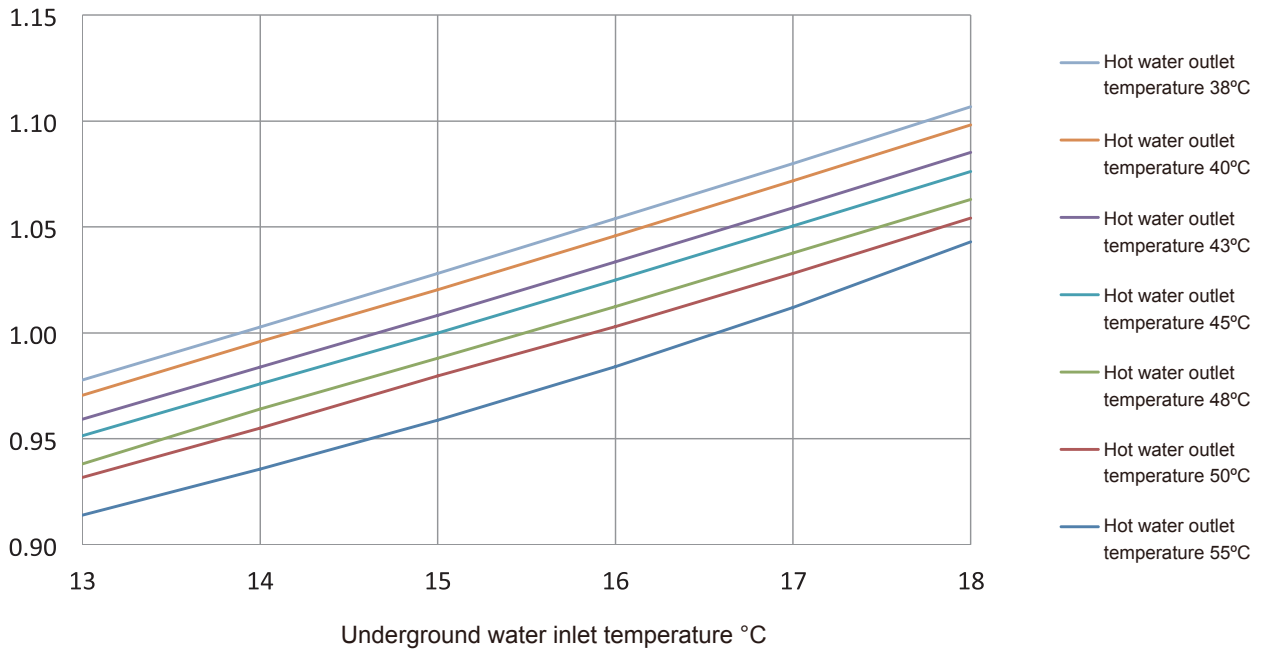

Input power correction factor diagram of the water source heat pump (underground water) (heating mode)

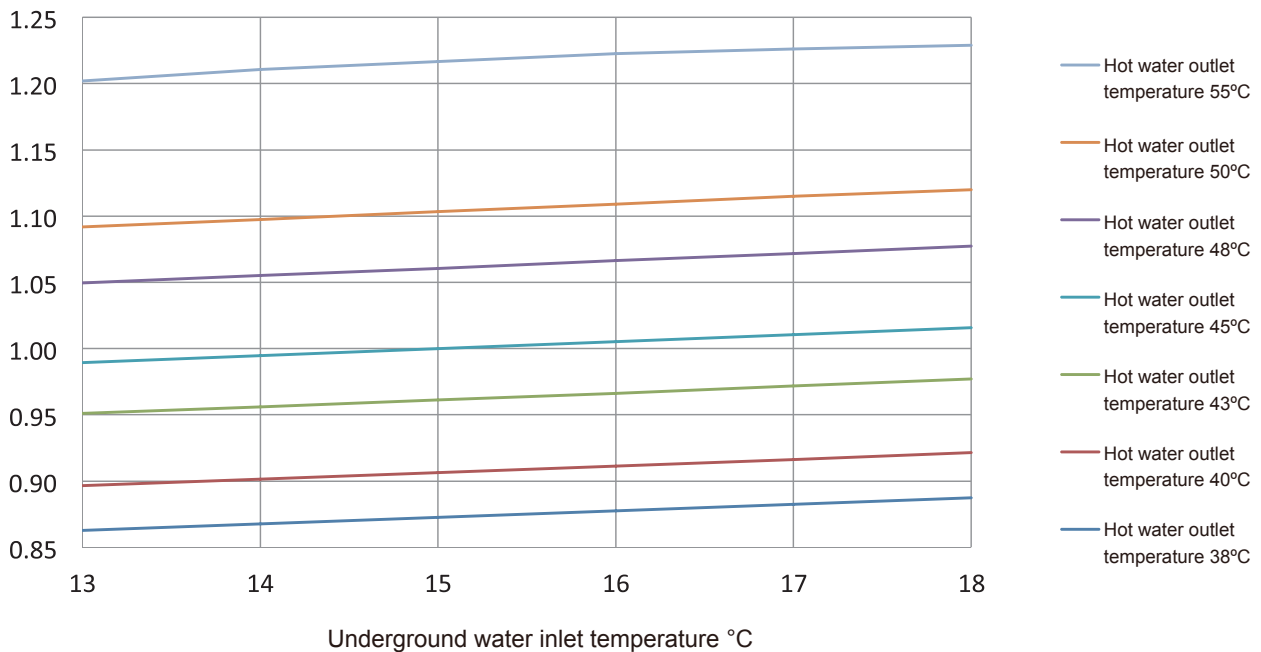

Cooling capacity correction factor diagram of the water source heat pump (geothermal) (cooling mode)

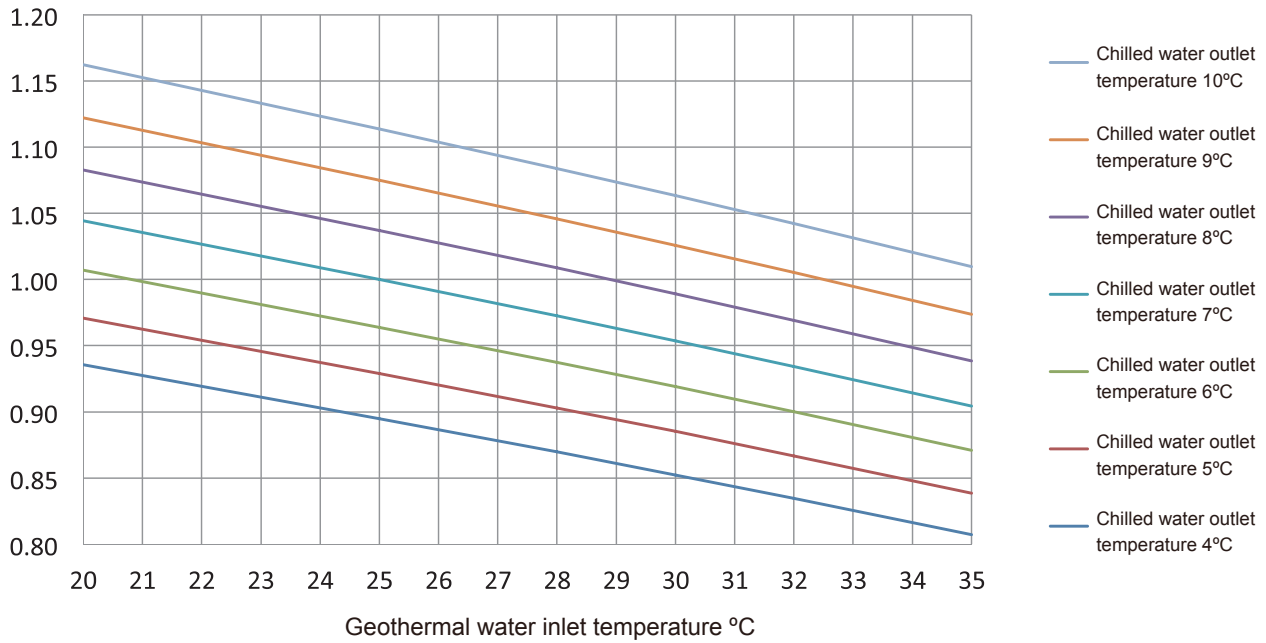

Input power correction factor diagram of the water source heat pump (geothermal) (cooling mode)

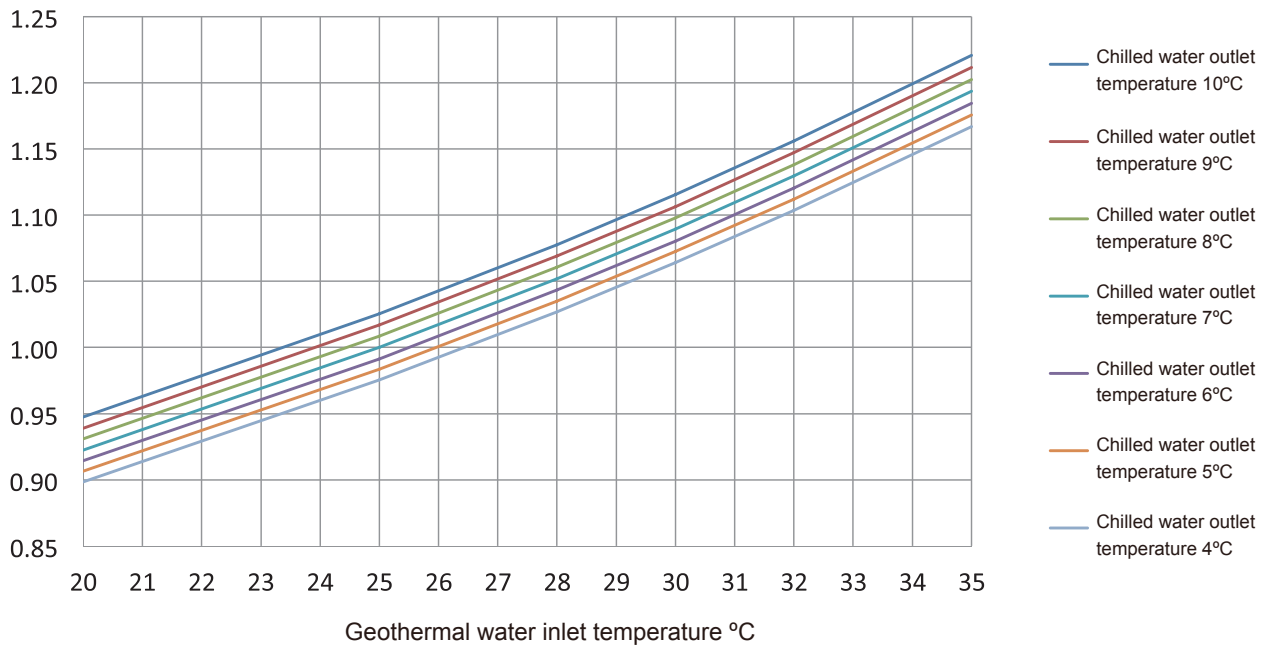

Heating capacity correction factor diagram of the water source heat pump (geothermal) (heating mode)

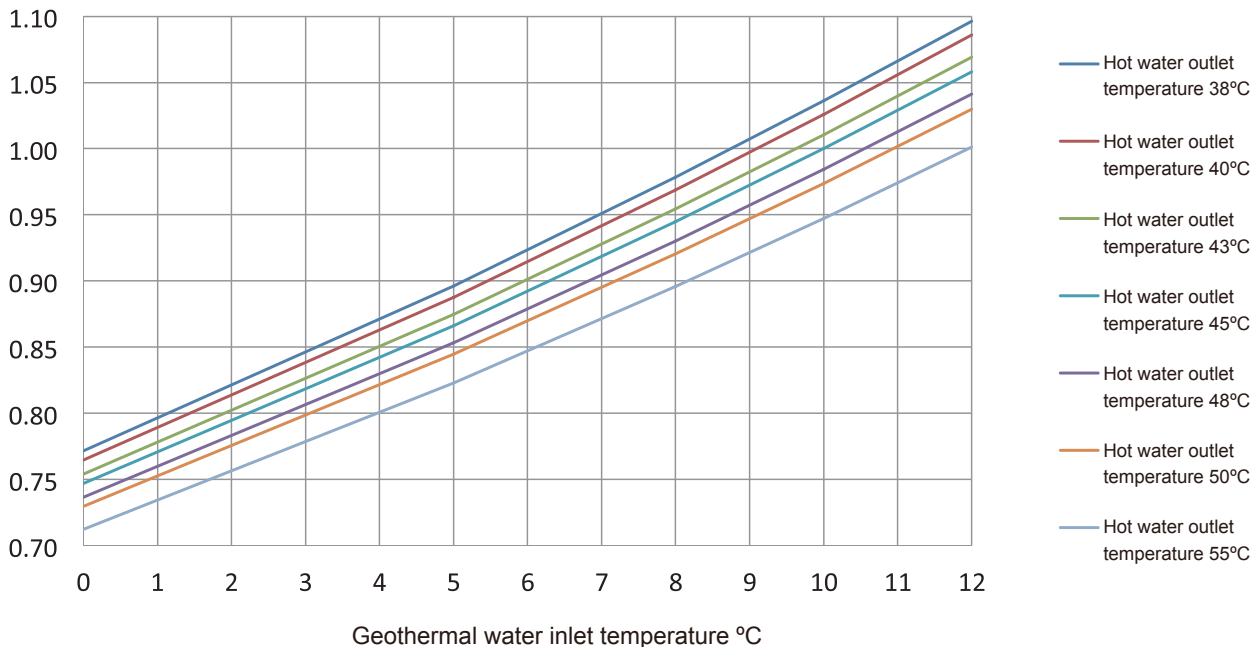

Input power correction factor diagram of the water source heat pump (geothermal) (heating mode)

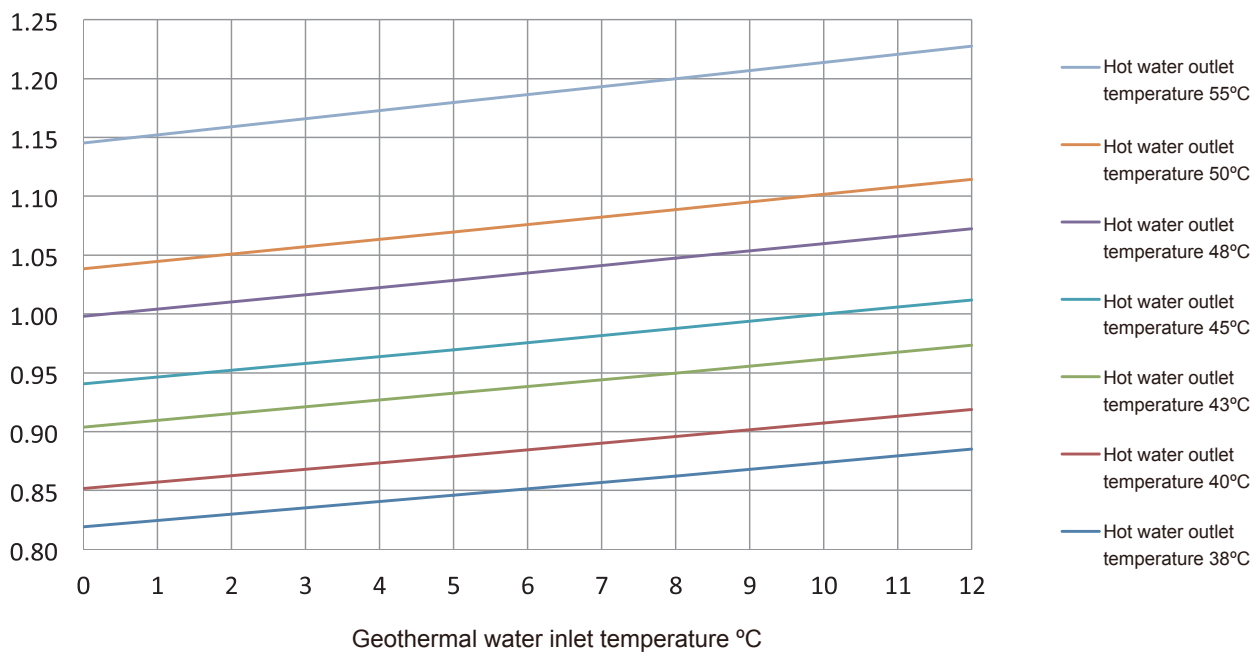

System

- ◆ Full heat recovery technology

The unit can effectively recycle the condensation heat to meet the usage requirement of warm water supply for domestic use of clients.

- ◆ Flow changing technology

Inverter water pump is equipped to reduce system pump power consumption, but to ensure stable operation of the system, please note that:

1. The chilled water flow ranges from 40% to 110% of the nominal flow.
2. The rate of change of water flow should not exceed 30% per minute, and the recommended rate of change of water flow is 10% per minute.
3. The water flow is recommended to fall within 0.8-3.0m/s. When the water flows too slowly, the heat transfer efficiency may be affected and the unit's efficiency may be compromised; when the water flows too quickly, it may lead to excessive voltage drop, thereby adversely impacting the unit's service life.
4. Cooling water flow should not exceed 110% of the nominal value. Variable chilled water flow design is recommended.

- ◆ Perennial cooling

Perennial cooling unit can be provided according to on-site situation.

Electric control

- ◆ Circuit breaker

Depending on customer requirements, circuit breakers may be added to further effectively protect the unit.

- ◆ Solid-state soft start

Depending on customer requirements, solid-state soft start may be equipped to lower the startup current of the unit and to reduce the impact on the power grid.

Container

- ◆ Water pipe connection mode: standard clamp connection, optional flange connection

- ◆ Water side pressure: standard unit container pressure is 1.0MPa (1.6MPa and 2.0MPa optional)

- ◆ Water pipe connection direction: Depending on the installation site conditions, the pipe direction may be varied

Others

- ◆ Shock absorbing device: The unit comes with 4 pieces of 30mm chloroprene rubber shock-absorbing cushions. Spring shock-absorbing cushions may be provided depending on customer's requirements.

- ◆ Bottom channel steel: Bottom channel steel may be provided depending on customer's requirements.

- ◆ Insulation: A standard unit is insulated with 20mm rubber and plastic insulation material. A 40mm thick layer of insulation may be provided upon request.

- ◆ Package: A standard unit is packed with heat shrinkable membrane. It may be also provided with a wooden box if required.

Note: For any additional requirements, please contact the local dealer of TICA.

Unit options – full heat recovery (for FW, FG heat pump units only)

The condensation heat recovery is to use heat exchange device to recover the waste heat from the condenser. Specifically, hot refrigerant exiting from the compressor will first enter the heat recovery device where it could exchange heat with running water to produce domestic or industrial hot water and will then enter the condenser to exchange heat.

The following figure shows the diagram of heat recovery process of domestic hot water.

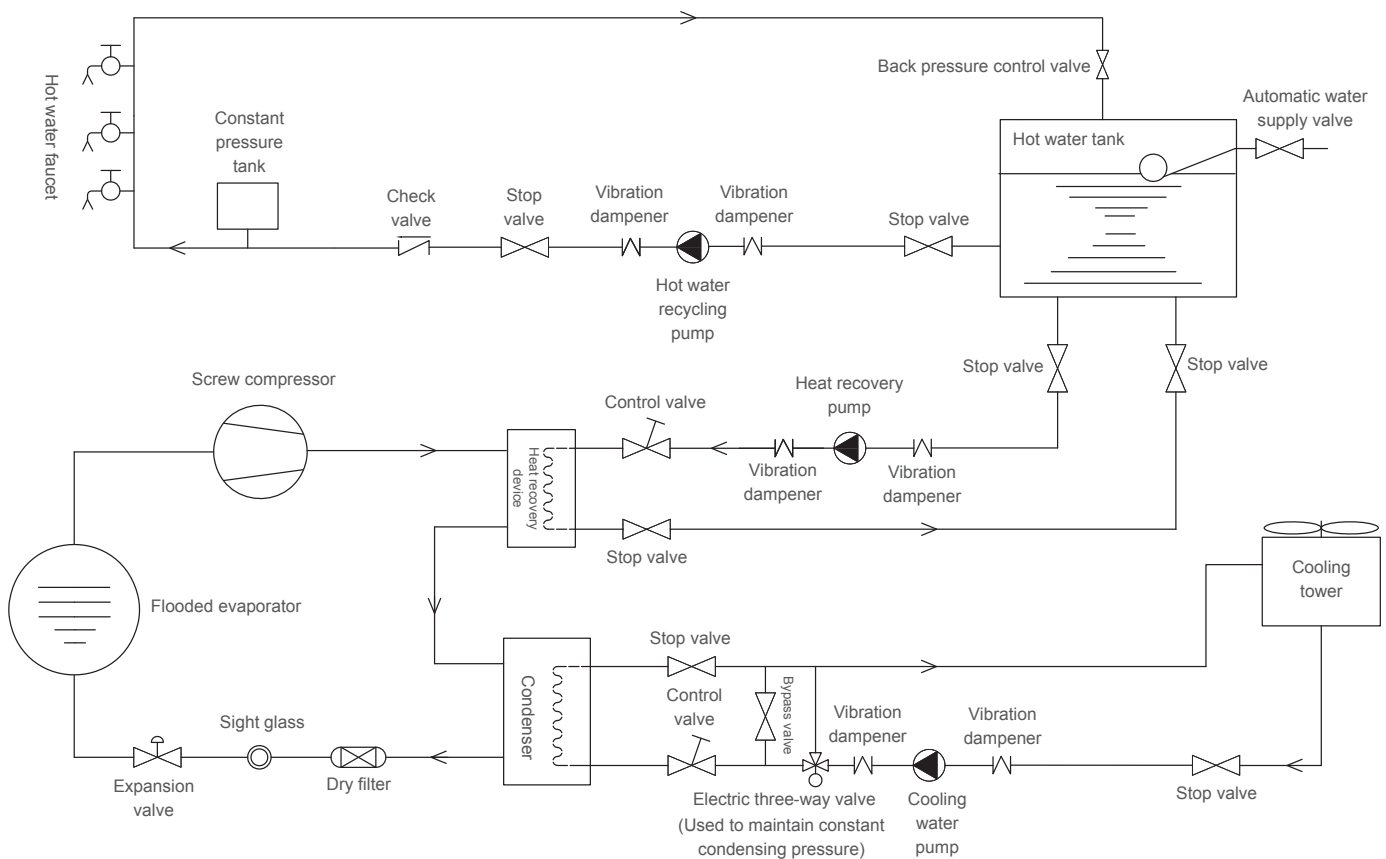

Full heat recovery parameters of the water-cooled flooded screw chiller (heat pump) (optional)

Model	Outlet water temperature: 45°C		Outlet water temperature: 50°C		Outlet water temperature: 55°C		Connector size DN
	Heat recovery capacity (kW)	Hot water flow (m ³ /h)	Heat recovery capacity (kW)	Hot water flow (m ³ /h)	Heat recovery capacity (kW)	Hot water flow (m ³ /h)	
TWSF0120.1FW1A	448	77	434	75	420	72	150
TWSF0140.1FW1A	506	87	489	84	470	81	150
TWSF0155.1FW1A	544	94	533	92	512	88	150
TWSF0180.1FW1A	643	111	622	107	600	103	150
TWSF0210.1FW1A	769	132	743	128	718	124	200
TWSF0230.1FW1A	828	143	800	138	773	133	200
TWSF0250.1FW1A	908	156	806	139	778	134	200
TWSF0270.1FW1A	976	168	938	162	907	156	200
TWSF0285.2FW1A	1047	180	1012	174	973	168	200
TWSF0305.2FW1A	1094	188	1054	182	1013	175	200
TWSF0330.2FW1A	1174	202	1150	198	1105	190	200
TWSF0355.2FW1A	1285	221	1250	215	1204	207	200
TWSF0375.2FW1A	1372	236	1326	228	1281	221	200
TWSF0400.2FW1A	1464	252	1415	244	1367	235	200
TWSF0420.2FW1A	1525	263	1474	254	1423	245	200
TWSF0440.2FW1A	1614	278	1560	269	1506	259	200
TWSF0465.2FW1A	1700	293	1616	278	1560	269	200
TWSF0495.2FW1A	1804	311	1745	301	1686	290	200
TWSF0520.2FW1A	1891	326	1829	315	1768	305	200
TWSF0540.2FW1A	1965	338	1900	327	1837	316	200
TWSF0120.1FG1A	442	76	427	74	414	71	150
TWSF0140.1FG1A	500	86	481	83	464	80	150
TWSF0155.1FG1A	536	92	516	89	496	85	150
TWSF0180.1FG1A	635	109	614	106	594	102	150
TWSF0210.1FG1A	760	131	735	127	710	122	200
TWSF0230.1FG1A	818	141	791	136	764	132	200
TWSF0250.1FG1A	896	154	866	149	836	144	200
TWSF0270.1FG1A	963	166	932	161	902	155	200
TWSF0285.2FG1A	1025	177	986	170	951	164	200
TWSF0305.2FG1A	1071	184	1031	178	992	171	200
TWSF0330.2FG1A	1150	198	1107	191	1064	183	200
TWSF0355.2FG1A	1259	217	1215	209	1172	202	200
TWSF0375.2FG1A	1344	232	1300	224	1257	217	200
TWSF0400.2FG1A	1435	247	1388	239	1341	231	200
TWSF0420.2FG1A	1494	257	1445	249	1396	240	200
TWSF0440.2FG1A	1581	272	1529	263	1477	254	200
TWSF0465.2FG1A	1664	287	1608	277	1554	268	200
TWSF0495.2FG1A	1766	304	1708	294	1651	284	200
TWSF0520.2FG1A	1850	319	1791	308	1733	299	200
TWSF0540.2FG1A	1923	331	1862	321	1802	310	200

★ Note:

1. Please contact the factory for the dimensions of full heat recovery unit.



Water-cooled Flooded Screw
Chiller (Heat Pump)

Unit Dimensions

—Single head high-efficiency series

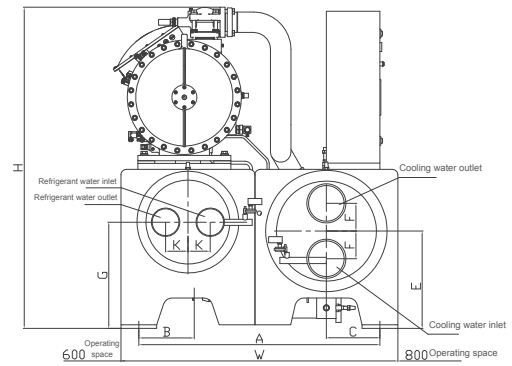
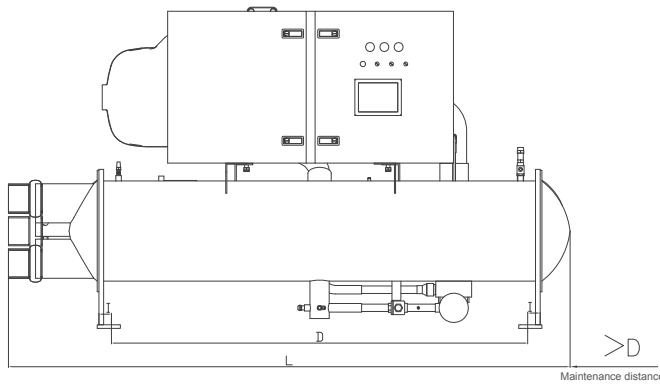

Model (TWSF-FC1)	Evaporator water inlet/outlet	Condenser water inlet/outlet	A	B	C	D	E	F	G	L	W	H	K	I
0110.1	DN150	DN150	1300	275	275	2330	495	125	595	3122	1500	1800	125	70
0135.1	DN150	DN150	1300	275	275	2330	495	125	595	3122	1500	1800	125	
0160.1	DN150	DN150	1300	275	275	2330	495	125	595	3122	1500	1800	125	
0175.1	DN150	DN150	1300	275	275	2330	495	125	595	3122	1500	1800	125	
0200.1	DN150	DN200	1350	275	300	2330	545	155	595	3144	1550	1850	125	
0220.1	DN150	DN200	1350	275	300	2330	545	155	595	3144	1550	1850	125	
0240.1	DN150	DN200	1350	275	300	2330	545	155	570	3144	1550	1850	130	
0265.1	DN150	DN200	1350	275	300	2330	545	155	570	3144	1550	1850	130	

Model (TWSF-FW(G)1)	Evaporator water inlet/outlet	Condenser water inlet/outlet	A	B	C	D	E	F	G	L	W	H	K	I
0120.1	DN150	DN150	1300	275	275	2330	495	125	595	3122	1500	1800	125	70
0140.1	DN150	DN150	1300	275	275	2330	495	125	595	3122	1500	1800	125	
0155.1	DN150	DN150	1300	275	275	2330	495	125	595	3122	1500	1800	125	
0180.1	DN150	DN150	1300	275	275	2330	495	125	595	3122	1500	1800	125	
0210.1	DN150	DN200	1350	275	300	2330	545	155	595	3144	1550	1850	125	
0230.1	DN150	DN200	1350	275	300	2330	545	155	595	3144	1550	1850	125	
0250.1	DN150	DN200	1350	275	300	2330	545	155	570	3144	1550	1850	130	
0270.1	DN150	DN200	1350	275	300	2330	545	155	570	3144	1550	1850	130	

★ Note:

1. The water inlet and outlet pipes of evaporator and condenser must be supported to avoid applying any external force to the unit.
2. The size of the equipment room area can guarantee repair and maintenance of the evaporator and condenser.

—Dual head high-efficiency series

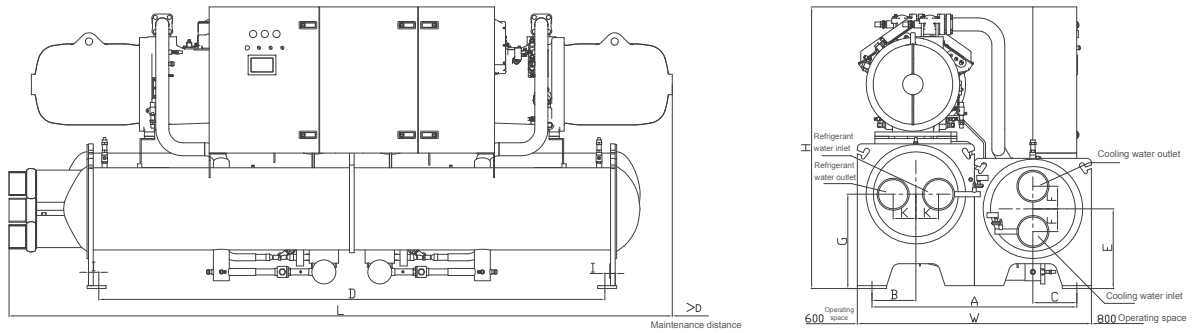

Model (TWSF-FC1)	Evaporator water inlet/outlet	Condenser water inlet/outlet	A	B	C	D	E	F	G	L	W	H	K	I
0280.2	DN200	DN200	1400	300	300	3460	545	155	645	4497	1600	1950	155	70
0300.2	DN200	DN200	1400	300	300	3460	545	155	645	4497	1600	1950	155	
0325.2	DN200	DN200	1400	300	300	3460	545	155	645	4497	1600	1950	155	
0350.2	DN200	DN200	1400	300	300	3460	545	155	645	4497	1600	1950	155	
0370.2	DN200	DN200	1600	350	350	3460	595	180	695	4540	1800	2050	180	
0390.2	DN200	DN200	1600	350	350	3460	595	180	695	4540	1800	2050	180	
0410.2	DN200	DN200	1600	350	350	3460	595	180	695	4540	1800	2050	180	
0430.2	DN200	DN200	1600	350	350	3460	595	180	695	4540	1800	2050	180	
0450.2	DN200	DN200	1600	350	350	3460	595	180	695	4540	1800	2050	180	
0465.2	DN200	DN200	1600	350	350	3460	595	180	695	4624	1800	2050	180	
0495.2	DN200	DN200	1600	350	350	3460	595	180	695	4624	1800	2050	180	
0510.2	DN200	DN200	1600	350	350	3460	595	180	695	4652	1800	2050	180	

Model (TWSF-FW(G)1)	Evaporator water inlet/outlet	Condenser water inlet/outlet	A	B	C	D	E	F	G	L	W	H	K	I
0285.2	DN200	DN200	1400	300	300	3460	545	155	645	4497	1600	1950	155	70
0305.2	DN200	DN200	1400	300	300	3460	545	155	645	4497	1600	1950	155	
0330.2	DN200	DN200	1400	300	300	3460	545	155	645	4497	1600	1950	155	
0355.2	DN200	DN200	1400	300	300	3460	545	155	645	4497	1600	1950	155	
0375.2	DN200	DN200	1600	350	350	3460	595	180	695	4567	1800	2050	180	
0400.2	DN200	DN200	1600	350	350	3460	595	180	695	4567	1800	2050	180	
0420.2	DN200	DN200	1600	350	350	3460	595	180	695	4567	1800	2050	180	
0440.2	DN200	DN200	1600	350	350	3460	595	180	695	4567	1800	2050	180	
0465.2	DN200	DN200	1600	350	350	3460	595	180	695	4567	1800	2050	180	
0495.2	DN200	DN200	1600	350	350	3460	595	180	695	4672	1800	2050	180	
0520.2	DN200	DN200	1600	350	350	3460	595	180	695	4672	1800	2050	180	
0540.2	DN200	DN200	1600	350	350	3460	595	180	695	4672	1800	2050	180	

★ Note:

1. The water inlet and outlet pipes of evaporator and condenser must be supported to avoid applying any external force to the unit.
2. The size of the equipment room area can guarantee repair and maintenance of the evaporator and condenser.

—Single head super high-efficiency series

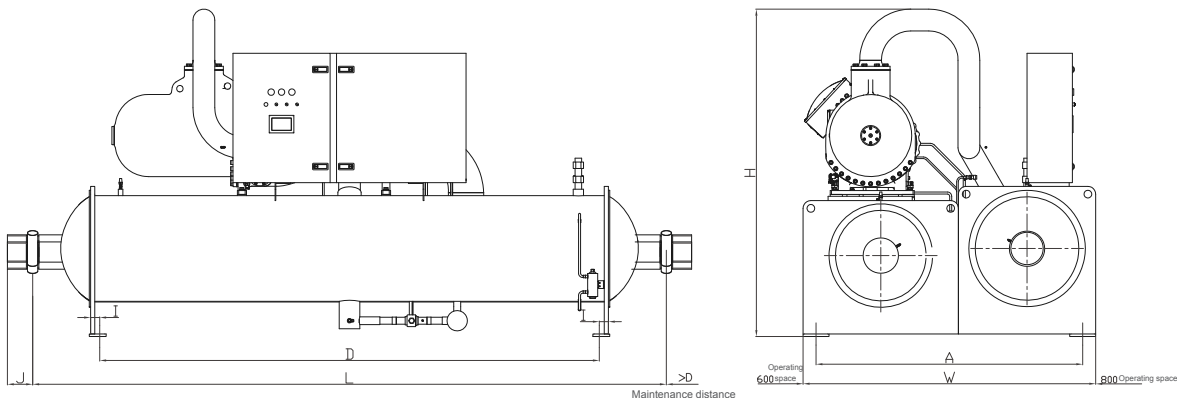

Model (TWSF-FC1)	Evaporator water inlet/outlet	Condenser water inlet/outlet	A	D	L	W	H	I	J
0430.1	DN200	DN250	2060	3460	4800	2260	2600	70	200
0450.1	DN200	DN250	2060	3460	4800	2260	2600		
0470.1	DN200	DN250	2060	3460	4800	2260	2600		

—Dual head super high-efficiency series

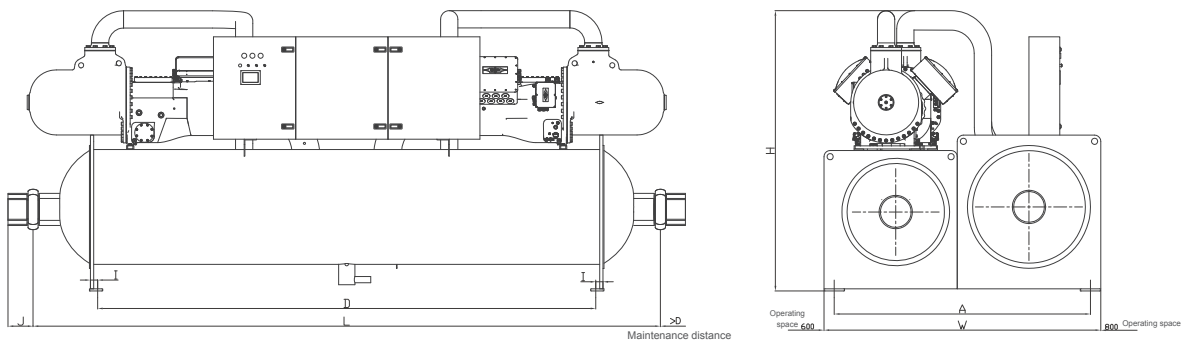

Model (TWSF-FC1)	Evaporator water inlet/outlet	Condenser water inlet/outlet	A	D	L	W	H	I	J
0850.2	DN250	DN300	2500	5360	6700	2700	2750	70	200
0900.2	DN250	DN300	2500	5360	6700	2700	2750		
0940.2	DN250	DN300	2500	5360	6700	2700	2750		

★ Note:

1. The water inlet and outlet pipes of evaporator and condenser must be supported to avoid applying any external force to the unit.
2. The size of the equipment room area can guarantee repair and maintenance of the evaporator and condenser.

Water-cooled Flooded Screw
Chiller (Heat Pump)

Lifting Diagram

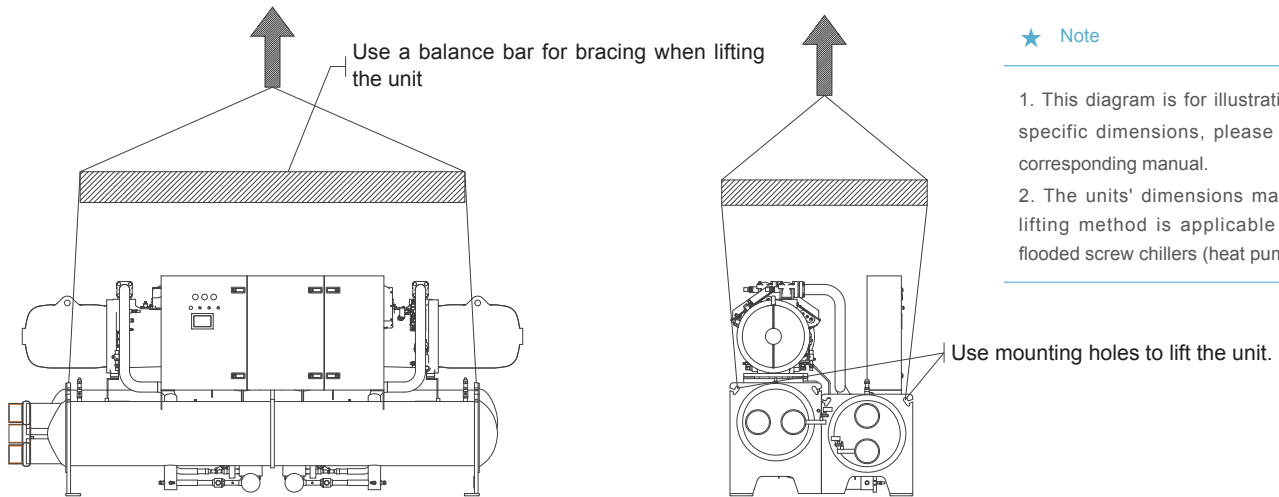

★ Note

1. This diagram is for illustration only. For specific dimensions, please refer to the corresponding manual.
2. The units' dimensions may vary. This lifting method is applicable to all TICA flooded screw chillers (heat pumps).

Water-cooled Flooded Screw
Chiller (Heat Pump)

Foundation Diagram

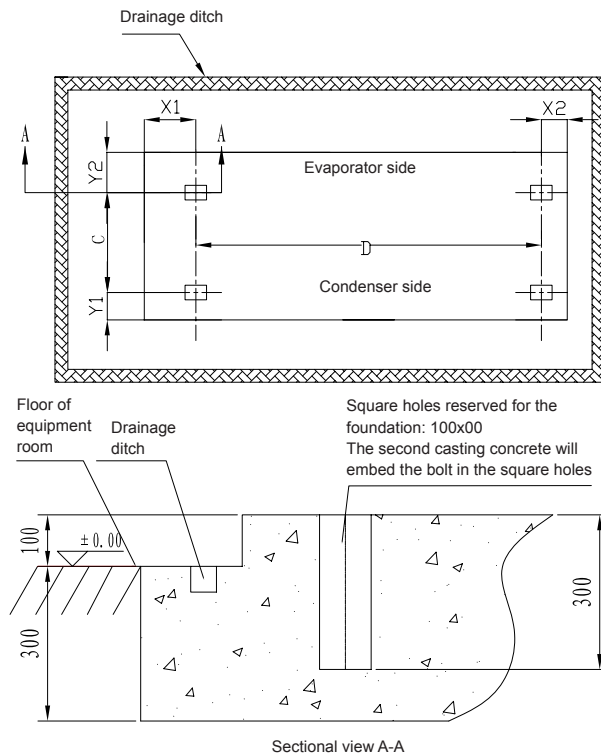

★ Note

1. The vibration of the unit is very small, so it can be placed on the concrete ground directly.
2. If the customer needs to build a foundation and use foundation bolts or expansion bolts to fix the unit, refer to the above figure to complete the construction and installation.
3. If the equipment room is built on the floor, the floor should have enough strength and stiffness to bear the operating weight of the chiller.
4. When building a concrete foundation, build a drainage ditch around the foundation to facilitate drainage, and make sure that the foundation edge is smooth.
5. The foundation is applicable to the left-type units. For right-type units, please switch X1, X2 values shown in the table.



WATER-COOLED FLOODED SCREW CHILLER

Model (TWSF-FC1)	D	C	X1	X2	Y1	Y2
0110.1	2330	1300	900	600	200	200
0135.1	2330	1300	900	600	200	200
0160.1	2330	1300	900	600	200	200
0175.1	2330	1300	900	600	200	200
0200.1	2330	1350	900	600	200	200
0220.1	2330	1350	900	600	200	200
0240.1	2330	1350	900	600	200	200
0265.1	2330	1350	900	600	200	200
0280.2	3460	1400	900	600	200	200
0300.2	3460	1400	900	600	200	200
0325.2	3460	1400	900	600	200	200
0350.2	3460	1400	900	600	200	200
0370.2	3460	1600	900	600	200	200
0390.2	3460	1600	900	600	200	200
0410.2	3460	1600	900	600	200	200
0430.2	3460	1600	900	600	200	200
0450.2	3460	1600	900	600	200	200
0465.2	3460	1600	900	600	200	200
0495.2	3460	1600	900	600	200	200
0510.2	3460	1600	900	600	200	200
0430.1	3460	2060	900	900	250	250
0450.1	3460	2060	900	900	250	250
0470.1	3460	2060	900	900	250	250
0850.2	5360	2500	1000	1000	250	250
0900.2	5360	2500	1000	1000	250	250
0940.2	5360	2500	1000	1000	250	250

Model (TWSF-FW(G)1)	D	C	X1	X2	Y1	Y2
0120.1	2330	1300	900	600	200	200
0140.1	2330	1300	900	600	200	200
0155.1	2330	1300	900	600	200	200
0180.1	2330	1300	900	600	200	200
0210.1	2330	1350	900	600	200	200
0230.1	2330	1350	900	600	200	200
0250.1	2330	1350	900	600	200	200
0270.1	2330	1350	900	600	200	200
0285.2	3460	1400	900	600	200	200
0305.2	3460	1400	900	600	200	200
0330.2	3460	1400	900	600	200	200
0355.2	3460	1400	900	600	200	200
0375.2	3460	1600	900	600	200	200
0400.2	3460	1600	900	600	200	200
0420.2	3460	1600	900	600	200	200
0440.2	3460	1600	900	600	200	200
0465.2	3460	1600	900	600	200	200
0495.2	3460	1600	900	600	200	200
0520.2	3460	1600	900	600	200	200
0540.2	3460	1600	900	600	200	200

The unit installation and maintenance must be carried out by professionals who have received professional training, get familiar with the local standards and rules, and have practical operation experience and qualifications of refrigeration equipment. The first operation of the unit must be carried out by the professional service department; otherwise, the quality of the unit is hardly guaranteed.

Arrival acceptance

After arrival of the equipment, carefully check whether all the items are complete against the packing list, and whether the parts are damaged during transportation; if any parts are damaged, notify the forwarder and put forward a written compensation request. Before installing the unit, make sure to check whether the local power supply voltage and frequency are suitable for the unit. Our company shall not bear the liability for compensation for any damages that arise after the acceptance of the goods.

Lifting

Be sure to use a cable twisted rope or chain with a sufficient bearing capacity to fasten the hoisting hole to hoist the unit, and operate according to the requirements of the hoisting diagram; make sure that the control cabinet and other parts of the unit are not damaged, and note to use spreader bar during hoisting. (Please refer to the above Unit Lifting Diagram).

Environmental requirements

The unit should be used indoors, the ambient temperature is above 4°C, and the relative humidity is not greater than 90%; the ground for installing the unit should be level and strong enough; otherwise, consider taking strengthening measures (refer to requirements in the above unit foundation diagram and maintenance space diagram); for the high salt environment, the unit should undergo salt tolerance treatment.

Water quality requirements

Because composition of water in different places is relatively complicated, if general water (such as industrial wastewater, groundwater, etc.) is used, the water quality should be checked before it enters the heat exchanger of the unit. If the water quality does not meet the requirement of air conditioning water, the water must be treated. Please refer to "GB50366-2009 Technical Code for Ground-source Heat Pump System", "GB50050-2007 Code for Design of Industrial Recirculating Cooling Water Treatment", "GB50296-2014 Technical Standard for Water-supply Well", "GB50027-2010 Specifications for Hydrological and Geological Survey of Water Supply" and other relevant standards. The unit's water must meet the following standards.

No.	Item	Unit	Allowable value
1	Sand content	-	<1/200000
2	Turbidity	mg/L	< 10
3	pH value (25°C)	-	6.5 - 8.0
4	Ca ²⁺ and Mg ²⁺ content	mg/L	<200
5	Fe ²⁺ content	mg/L	<0.5
6	Cl ⁻ content	mg/L	<100
7	SO ₄ ²⁻ content	mg/L	<200
8	H ₂ S content	mg/L	<0.5
9	Silicic acid content	mg/L	<175
10	Product of Mg ²⁺ and SiO ₂	mg/L	<15000
11	Free chlorine content	mg/L	0.5 - 1.0
12	Degree of mineralization	mg/L	<350
13	Oil pollutant content	mg/L	<5

Water pipe installation

Check valves must be installed at the unit inlet and outlet to facilitate routine maintenance of the water system. It is advised to install a thermometer and a pressure gauge at the water inlet and outlet of the heat exchanger for the unit to facilitate routine inspection and maintenance; install a water filter at the water inlet of the pump to prevent impurities from entering the pump and heat exchanger; check the pipeline seal in advance before the water pipe is insulated and water enters the unit; install a damping device on all the pipelines connected to the unit; install a flow control device meeting requirements (unit is equipped with the water flow switch); keep away from the water inlet and outlet pipes of the heat exchanger of unit when installing drainage devices for the water system of air conditioning engineering, otherwise normal use of the unit will be affected.

External Water Pipe Connection Diagram of Cooling Only Unit

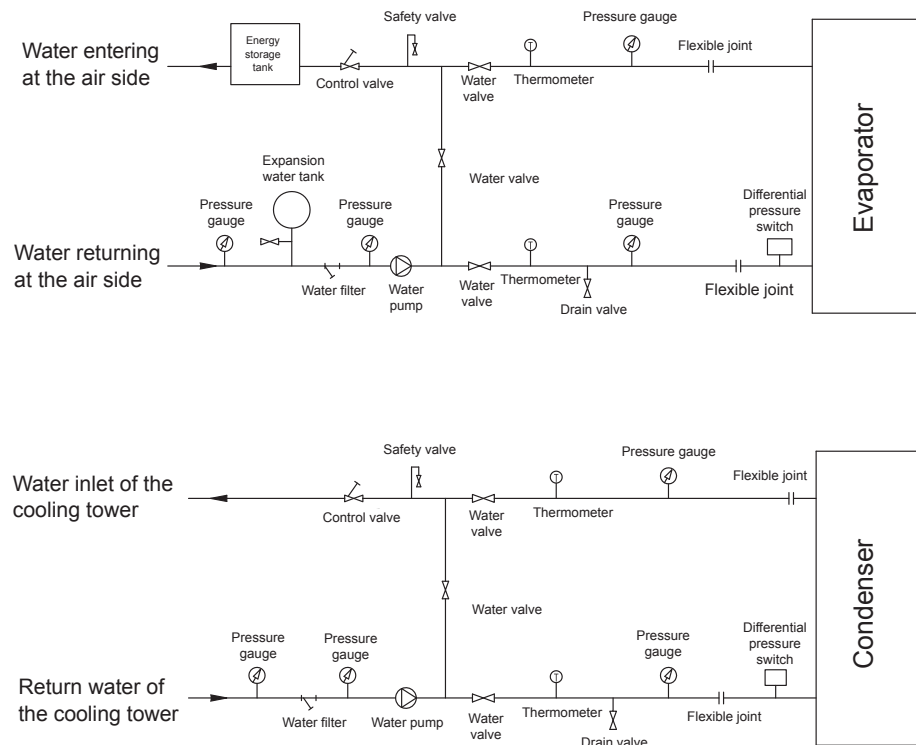

Notes for pipeline design and installation:

1. Water cycling system shall be designed as simple as possible and avoiding too many elbows. Straight pipes shall be arranged on the same plane where possible.
2. Pay attention to the water inlet and outlet positions of condenser and evaporator lest any connection errors take place.
3. Install manual or automatic air release valve at the top points of water cycling system.
4. The expansion tank should be anti-corrosive and rust proof and installed at the highest points of entire pipeline system.
5. Install a thermometer and a pressure gauge at the chilled and cooling water inlets and outlets respectively.
6. Install drain valves at the bottom of all local elbows to make sure the water in the whole system is emptied.
7. Install check valves at the chilled water and cooling water pipeline connecting the unit heat exchanger to the user's water pipe.
8. Install bypass valves between water inlet and outlet pipes of heat exchanger for future maintenance and pipeline rinsing.
9. Install flexible joints to reduce vibration of pipelines.
10. Install filters before water pumps because impurities will cause fouling of the heat exchanger.
11. To boost cooling (heating) performance and save energy, pipelines shall be completely insulated.
12. To prevent frequent trip of the unit due to the load too small, it is recommended to install an energy storage tank.
13. The pipes must not exceed the permissible maximum water flow.
14. The pipes and connectors directly connected to containers should be easy to disassemble to facilitate cleaning and appearance check of the heat exchanger joint.

External Water Pipe Connection Diagram of Heat Pump Unit

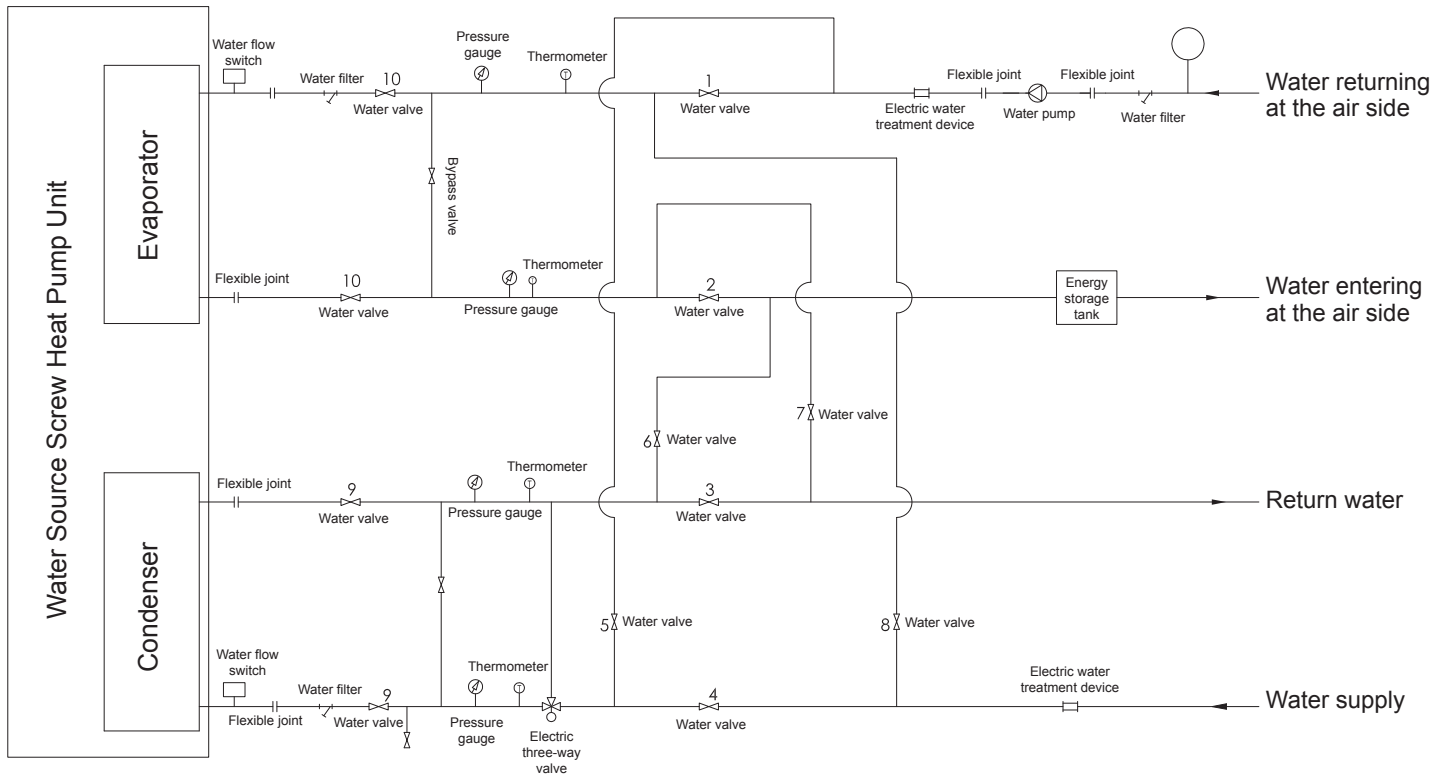

Cooling in summer: valves 1, 2, 3, 4, 9, 10 closed; valves 5, 6, 7, 8 opened
 Heating in winter: valves 1, 2, 3, 4 closed; valves 5, 6, 7, 8, 9 and 10 opened

Recommended Glycol Solution Concentration

Water Outlet Temperature °C	3 ~ 0	0 ~ -5	-5 ~ -10
Recommended Mass Concentration %	20	25	35

Water System Diagram of Heat Pump Unit

Underground water type

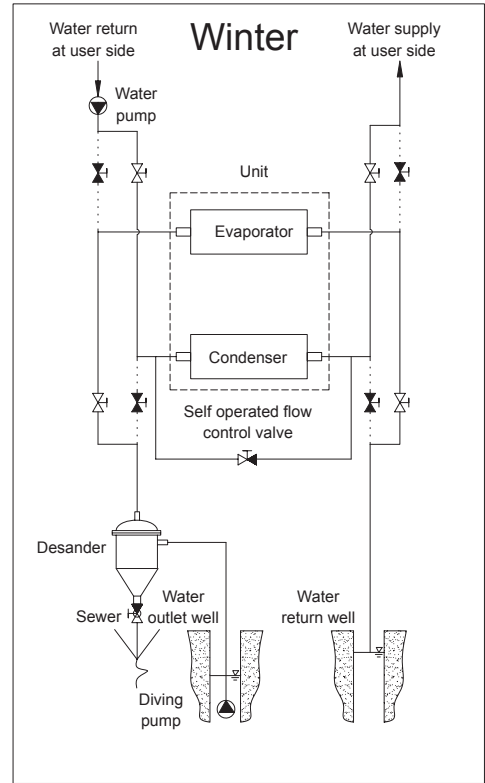
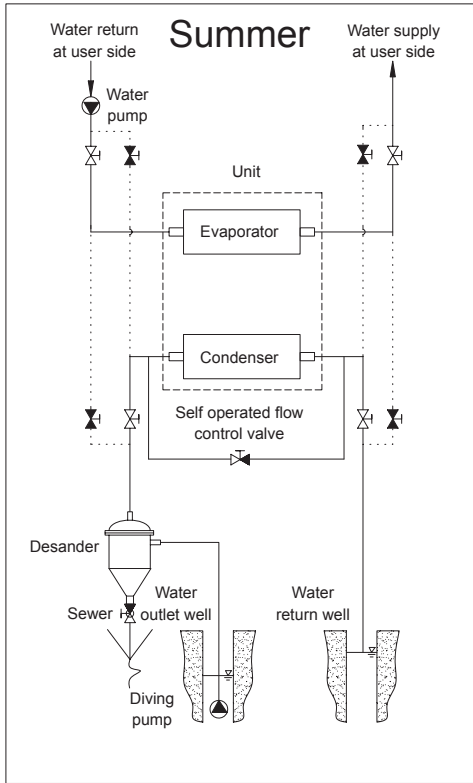

Geothermal type

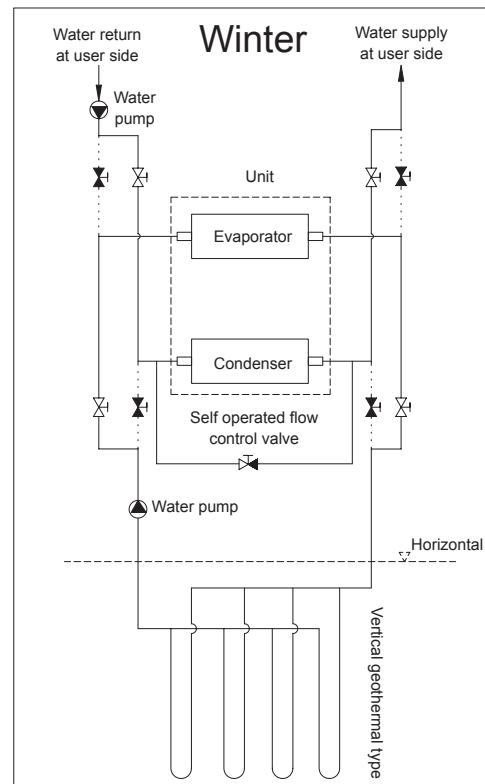
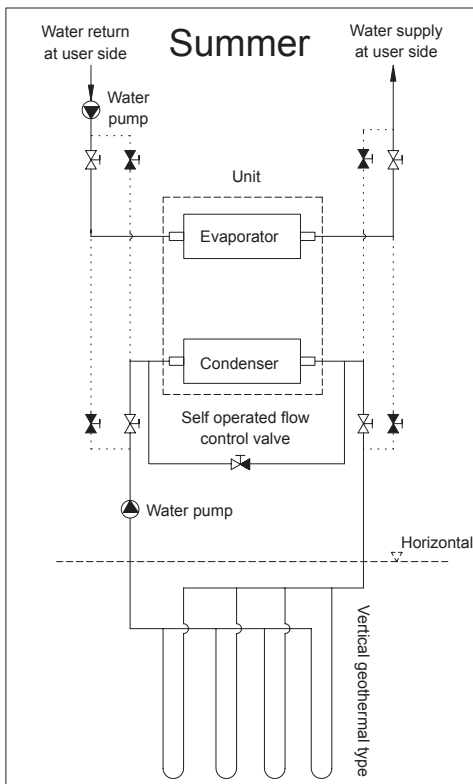

◆ Check valve:

Determine the valve according to the water pipe diameter. Usually the pipe diameter of the selected valve is consistent with the connected pipe diameter of the unit.

◆ Water filter:

It is used to filter the impurities from the water system. Usually select a filter with more than 60 meshes.

◆ Check valve:

It is installed at the water pump outlet to prevent damage to the water pump when water flows back. The valve pipe and unit connecting pipe are consistent in the diameter.

◆ Bypass valve:

It is installed between the inlet water pipe and outlet water pipe of the unit container. Open this valve when cleaning the pipeline.

◆ Thermometer:

Facilitates repair and maintenance and observes unit running. Usually the range of 0 to 100°C is selected.

◆ Water pump:

The water capacity of water pump is selected according to the water flow parameters of the unit:

Pump water capacity = $L \times 1.1$ (L - Unit water flow); the pump lift is calculated according to the following formula:

Pump head = {Unit water resistance + Most unfavorable pipe length * (2%-5%) + Water resistance at the end of the most unfavorable path} * 1.1

◆ Automatic air discharge valve:

It is installed on the highest point of the system and used to discharge air from the water system and make the unit operate normally.

◆ Expansion water tank:

Accommodates excessive water, stabilizes the water pressure in the system, and supplements the water in the system. Generally it is installed at the return water pipe, higher than the water pipe in the system, so that the unit can operate properly. Its capacity is calculated according to the following formula:

Expansion water tank volume $V = (0.03 \text{ to } 0.04) V_c$

V_c —System water capacity

◆ Energy storage tank:

It is used to regulate the energy to reduce the start/stop frequency of the compressor when the air conditioning system load changes, improve the system operation efficiency, and prolong the service life of the unit.

Its capacity is calculated according to the following formula:

Energy storage tank volume $V (m^3) = (Q/27.9n) - VS$

Q — Cooling capacity (kW)

n — Number of heads

VS — Pipeline in the chilled water system and water capacity (m^3) in the heat exchanger

◆ Minimum water volume:

Minimum water volume of the water circulation system is calculated by the following formula: Volume = CAP (kW) × N (L)

Operating types	N
Air-conditioning conditions	3.25
Process conditions	6.5

Where, CAP (kW) is the nominal cooling capacity of the unit under standard operating conditions.

This water capacity is required for stable operation and accurate temperature control of the unit. It is usually necessary to add a tank (with baffle plate) to reach the required capacity. The tank has a built-in baffle plate to ensure adequate mixing (water or saline).

See examples below.

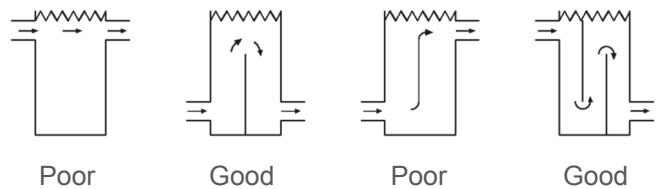

★ Note

- The tested pressure value of the pipeline pressure test is greater than 1.25 times the operating pressure, but not less than 0.6 MPa. When the pressure is maintained for 5 minutes, the pressure drop is not greater than 0.02 MPa. The system is qualified when leakage is not detected.
- The test can be conducted at temperature higher than 5°C. The pressure gauge must be checked and its precision should not be smaller than 1.5 and the highest measurable pressure is 1.5~2 times of the maximum test pressure.
- Water is added from the lower part of the system and air is discharged from the upper part. During the pressure test, add water slowly and evenly to reach the pressure, stop the pump, and check the system. Repair cannot be performed when there is pressure in the system.
- After the pressure test is qualified, rinse the water pipeline repeatedly (do not pass the equipment) till impurities such as silt and iron filings are not contained in the drained water and water is clear.

Water-cooled Flooded Screw Chiller (Heat Pump)

Check Items Before Startup

Waterway part

Check all the water system pipelines and confirm that the waterway connections of evaporator and condenser are connected correctly and the water flow direction is correct, check if the above-mentioned water inlet and outlet pipes of heat exchanger are well connected, open all the water valves and start the related pumps. Rinse the water pipes to ensure cleanness of the water system, and check all the water pipes and joins for leakage. Discharge air from the evaporator and condenser waterways, keep the waterways clean and free of rust stains, test the water side resistance loss of the evaporator and condenser, and check if the water quantity is proper; make sure that the temperature sensor is connected correctly.

Circuit part

Disconnect the main isolating switch and check all the starting circuits and control circuits of the control cabinet. Make sure that all the switches are disconnected. Check the power supply for the unit. Its voltage fluctuation range cannot exceed $\pm 10\%$ of the rated voltage indicated on the unit nameplate, and the phase voltage unbalance cannot exceed 2%; check if there is enough power supply capacity to meet the startup and full load operation conditions of the unit. Confirm that all the wire and fuse specifications match operation of the unit, and complete all the interlocking control lines according to the relevant electric control drawings. Make sure that all the air conditioning accessories and control devices operate properly, and the sufficient cooling capacity can be provided to meet the unit operation requirements when the unit operates for the first time.

Unit part

Make sure that the compressor oil heater has been powered on for more than 3 hours. Observe the oil level from the sight glass. If oil level cannot be seen, add oil. Open the discharge check valve completely and turn it 1/2 turn clockwise. Start the liquid supply check valve, air conditioning accessories, condensate water pump and chilled water pump, and check if all the safety control devices are in the original state and if their settings are correct. For the related check items, refer to <Table 1> below.

Safety device

The unit is equipped with safety protection devices to ensure safe operation. When a safety device operates, the fault indicator is turned on, this part of the function will stop, and the other parts are still normal. You are advised to stop the unit and locate the cause even if a part becomes abnormal, lest the unit would suffer a more severe accident. For the specific safety device series on the unit, see <Table 2>.

Table 1 Unit safety devices

Safety device	Possible cause
High pressure protection	1. The fluorine system valve is not open
	2. Insufficient cooling water flow
	3. Dirt deposits on the condenser
	4. Non-condensable gas exists in the system
Freezing protection	1. Chilled water temperature is too low
	2. Set temperature is too low
Discharge gas temperature protection	1. Low refrigerant level due to leak
	2. Solenoid valve closed due to a fault
	3. Improper adjustment of the discharge superheat degree
Motor overheat protection (compressor motor protection)	The same as high pressure protection
Low pressure protection	1. The liquid supply solenoid valve fails or the dry filter is blocked
	2. The expansion valve is improperly adjusted
	3. Insufficient chilled water flow
	4. Evaporator fouls
Phase sequence protector	Power connection error
Over-current relay (compressor motor)	The same as high pressure protection
Safety valve	Refrigerant system exceeds the pressure

Table 2 Recommended operating ranges of the unit

Water-cooled Screw Chiller

Item		Standard operating condition	Continuous operation area
Cooling condition	Cooling water inlet temperature °C	30	16 - 40
	Chilled water outlet temperature °C	7	4 - 15

Water Source Screw Heat Pump Unit

Item		Standard operating conditions (TWSF-W/G)	Continuous operation area (TWSF-W/G)
Cooling condition	Condenser outlet temperature °C	29/30	20 - 42
	Evaporator outlet temperature °C	7	4 - 16
Heating condition	Condenser outlet temperature °C	45	35 - 60
	Evaporator outlet temperature °C	7/5	4 - 16

Note: For operation under the extreme conditions, the user is advised to configure a three-way valve (used for the constant condensation pressure) for stepless regulation of the water flow.

Routine Maintenance

TICA recommends the user record the routine operating data of air-conditioning equipment and regularly carry out maintenance.

1. Before using the unit for the first time, check the functioning of the air side equipment and other parts of the water system.
2. (Recommended) Use the following service schedule to maintain the unit:

Daily inspection		1. Check whether the unit generates any alarm						
		2. Check whether the air discharge and air suction pressures and oil pressure are normal						
		3. Check whether the oil level is normal (check through the oil sight glass to ensure proper amount of oil)						
		4. Check for any abnormal compressor noise						
		5. Check for odors inside the startup cabinet and control cabinet						
		6. Check whether the temperature sensor and temperature probe are securely fixed						
		7. Check for any appearance damage of the unit						
		8. Check whether the cooling tower, water pump, and valve function normally						
		9. Check the appearance of water pipes for damages and leakage						
Monthly inspection		1. Check the coil of compressor oil (the oil should be clear and clean; if the color turns dark brown or muddy, replace the oil; if the oil turns black, disassemble and inspect the compressor)						
		2. Check the color of the test paper in the sight glass of liquid supply pipe (yellow indicates that the refrigerant has excessive water content)						
		3. Check for leakage in the refrigerant loop (whether there is any greasy dirt or sound of leak)						
		4. Clean the startup cabinet and control cabinet						
		5. Check cleanliness of the water line filter, and clean the filter when necessary						
		6. Check the water quality, and send the water sample for laboratory analysis if possible (water quality should comply with the standard Code for Design of Industrial Recirculating Cooling Water Treatment or other relevant standards)						
Inspection Based on Service Life or Runtime		1 year	2 years	3 years	4 years	5 years	Exceptions	
		1000 hours	3000 hours	5000 hours	7000 hours	9000 hours		
Compressor	Motor				☆		Insulation resistance is abnormal.	
	Solenoid valve	☆	☆	☆	☆	☆	Insulation resistance is abnormal.	
	Oil heater	☆	☆	☆	☆	☆	Insulation resistance is abnormal.	
	Compressor oil filter	★	★	★	★	★	Oil pressure alarm	
	Lubricant	★	★	★	★	★	Discoloration or turbidity	
Refrigerant filter	★	★	★	★	★			
Heat exchanger	Evaporator and condenser		★	☆	★	☆	Temperature difference for heat exchange exceeds 3°C	
	Check the water inlet/outlet pressure difference (refer to the table of unit specifications)	★	★	★	★	★	Water pressure difference is too large or too small. Adjust the water flow until it meets the requirements.	
Valves	Solenoid valve	☆	☆	☆	☆	☆	Cannot be opened or closed normally	
	EXV						Check the resistance and opening	
	Float valve	☆	☆	☆	☆	☆	The valve cannot ensure normal liquid supply.	
Electric	Fuse	☆	☆	☆	☆	☆	Disconnection	
	Contactors	☆	☆	☆	☆	☆	Serious contact electrocorrosion or noise during running.	
	Sensor	☆	☆	☆	☆	☆	Measured value still varies from the actual value even after calibration.	
	High pressure switch	☆	☆	☆	☆	☆	Controller false alarm.	
	Fastening wiring terminal	★	★	★	★	★	The contactor gets loose or can flexibly rotate when turning the connecting cable.	
	Checking power supply	★	★	★	★	★	Rated voltage ±10%, phase-to-phase unbalance < 2%.	
	Checking phase	★	★	★	★	★	No phase loss or reverse phase	

Notes:

- ① ★----Required maintenance or replacement items; ☆---- Determine the maintenance items according to actual conditions.
- ② Daily and monthly inspections should be performed and recorded by the user.
- ③ The replacement of consumable parts and materials is determined by the service life or operation duration of the unit. For units that operate all year around and those for the purpose of process, the operation duration should prevail; for units under normal operation and those for comfort, the service life should prevail.
After the initial 1000-hour operation of the unit, replace the lubricant, oil filter, and other filters in the refrigerant system.
After that, perform laboratory analysis on the refrigerant and oil every 2000 operating hours, to check whether the refrigerant or oil needs to be replaced.
Relevant sealing pad shall also be replaced when replacing the lubricant and filter.
- ④ Consumable parts and materials include refrigerant, refrigerant oil, oil filter, dry filter element, dry filter screen, filter screen of electric cabinet, battery, water side sealing pad, etc.



Follow the WeChat Official
Account of TICA

4008-601-601

NANJING TICA CLIMATE SOLUTIONS CO., LTD.

Address: No.6, Hengye Road, Nanjing Economic and Technological
Development Zone, China Postal code: 210046

Tel: 86-25-85326977

E-mail: tica@ticachina.com

Note: Due to constant improvement and innovation of TICA's products, the product models, specifications and parameters contained in this document are subject to change without prior notice.